

1. SPECIFICATIONS



SPECIFICATIONS	1-2	PTO DIMENSIONAL DRAWINGS	1-5
PERFORMANCE CURVE	1-3	WIRING DIAGRAMS	1-6
DIMENSIONAL DRAWINGS	1-4		

SPECIFICATIONS

SPECIFICATIONS

DIMENSIONAL AND WEIGHT

Model	GX100	
PTO type	Q	VEL
Overall length	295 mm (11.6 in)	278 mm (10.9 in)
Overall width	304 mm (12.0 in)	
Overall height	402 mm (15.8 in)	
Dry weight	10.6 kg (23.4 lbs)	
Operating weight	11.6 kg (25.6 lbs)	

ENGINE

Model	GX100
Description code	GCANM
Type	4-stroke, overhead camshaft
Total displacement	98 cm ³ (6.0 cu-in)
Bore and stroke	56 x 40 mm (2.2 x 1.6 in)
Maximum horsepower	2.2 kW (3.0 PS) at 3,600 min ⁻¹ (rpm)
Maximum torque	5.7 N·m (0.59 kgf·m, 4.2 lbf·ft) at 3,600 min ⁻¹ (rpm)
Compression ratio	8.5:1
Fuel consumption	327 g/kW·h (240 g/PS·h, 1.18 lb/hp·h)
Cooling system	Forced-air
Ignition system	Transistorized magneto ignition
Ignition timing	25° B.T.D.C
Spark plug	CR5HSB (NGK), U16FSR-UB(DENSO)
Carburetor	Horizontal type, butterfly valve
Air cleaner	Dual element type
Governor	Centrifugal mechanical governor
Lubricating system	Splash
Oil capacity	0.40 liters (0.42 US qt, 0.35 lpm qt)
Recommended operating ambient temperature	-15 °C -40 °C (5 °F -104 °F)
Starting system	Recoil starter
Stopping system	Ignition primary circuit ground
Fuel used	Automotive unleaded gasoline (minimum 86 pump octane)
Fuel tank capacity	1.2 liters (0.32 US gal, 0.26 lpm gal)
PTO shaft rotation	Counterclockwise (viewed from PTO side)

PERFORMANCE CURVE

Power curves are according to SAE standard No. J-1995. For practical operations, the bhp load and engine speed should not exceed the limit defined by the "Recommended Maximum Operation bhp" curve.

Continuous operation should not exceed 80% of the "Maximum bhp"

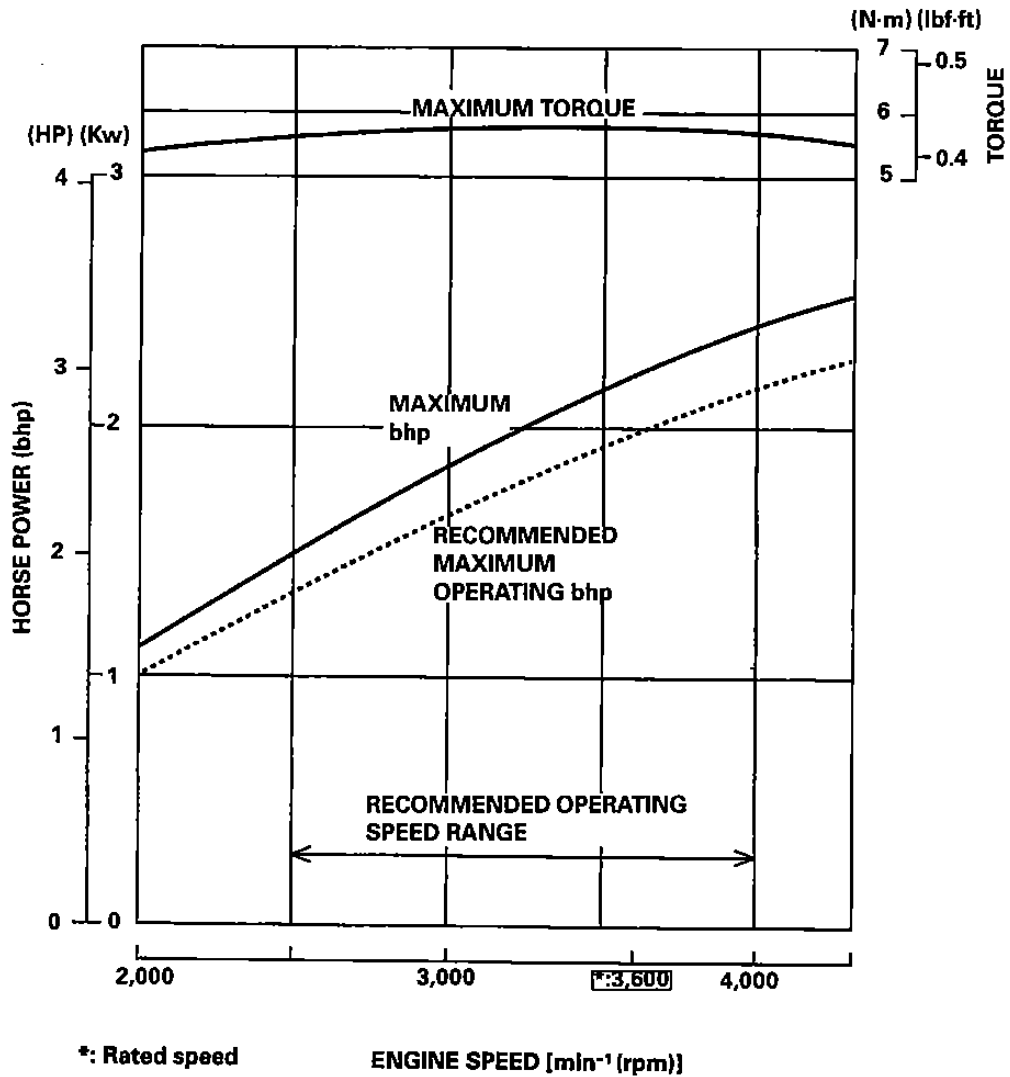

SPECIFICATIONS

DIMENSIONAL DRAWINGS

Unit:mm (in)

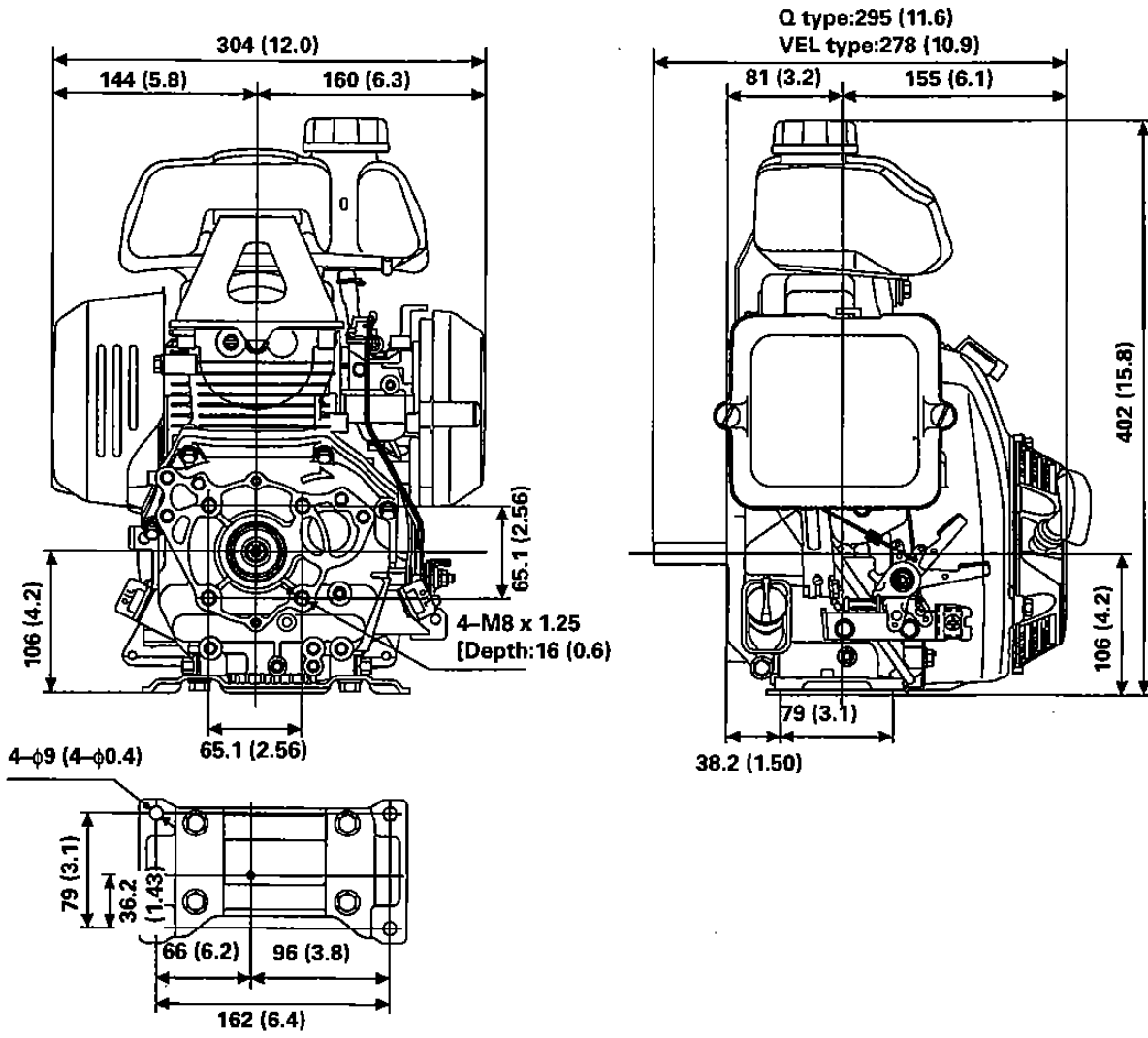

PTO DIMENSIONAL DRAWINGS

Unit:mm (in)

Q type:

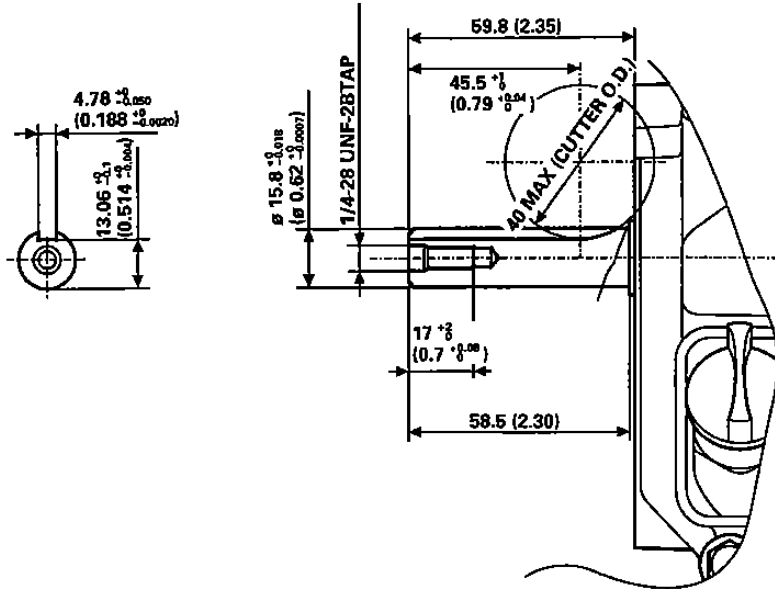

VEL type:

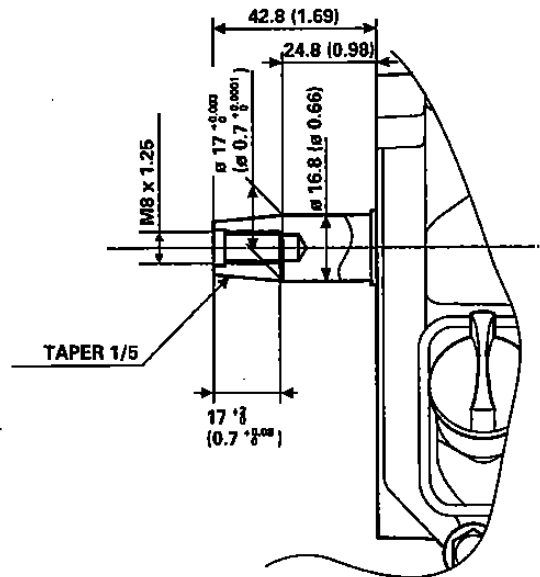

SPECIFICATIONS

WIRING DIAGRAMS

Type with oil alert:

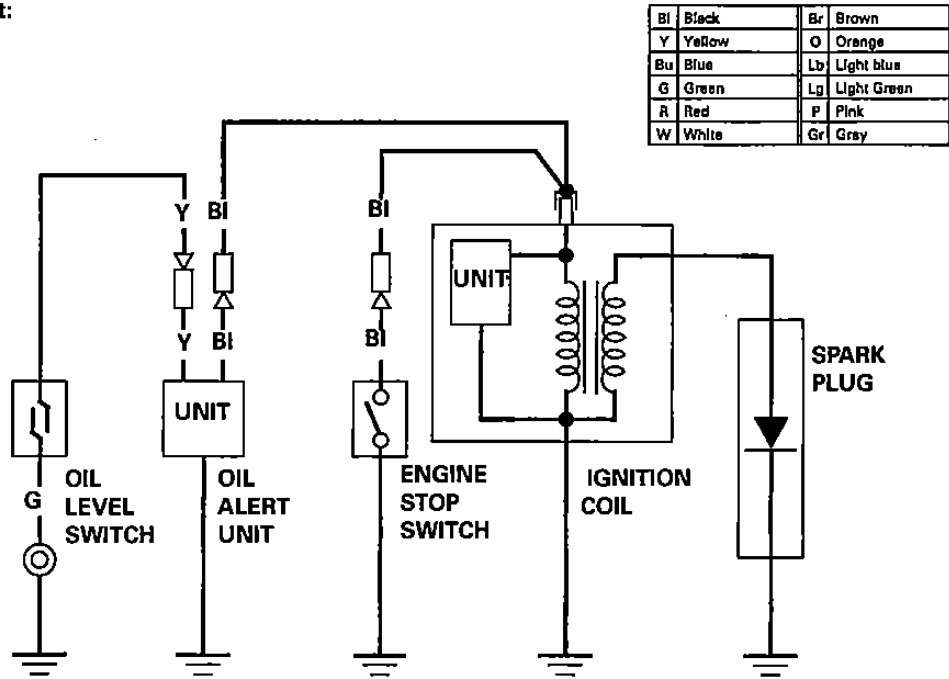

Type without oil alert:

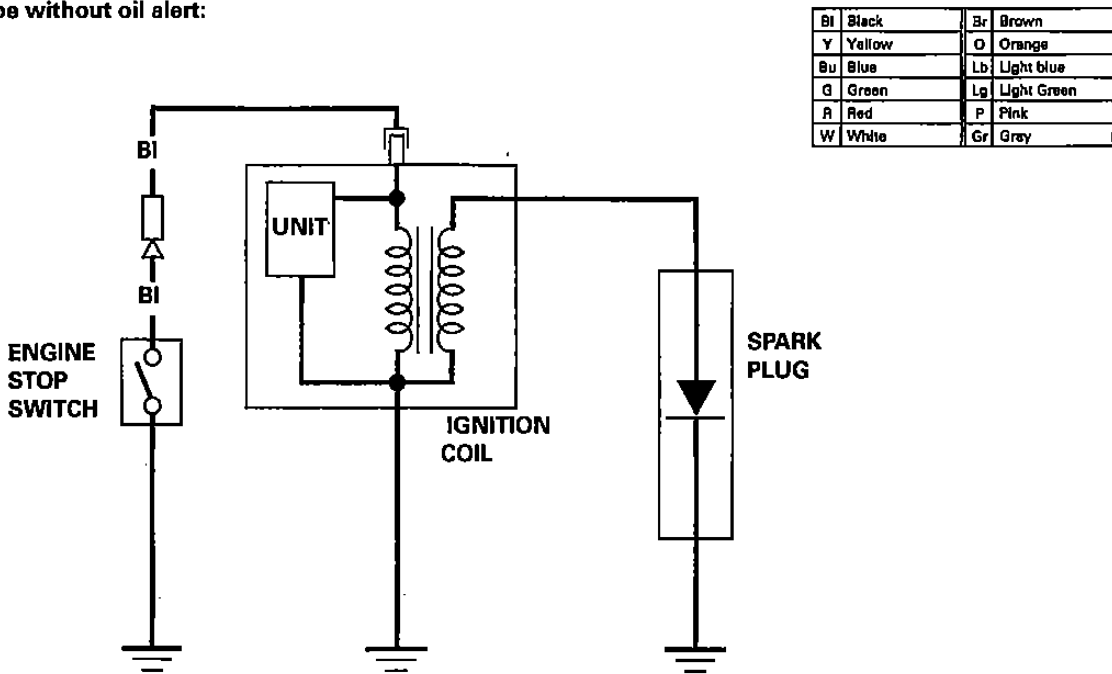

2. SERVICE INFORMATION



SYMBOLS USED IN THIS MANUAL	2-2	SPECIAL TOOLS	2-5
SERIAL NUMBER LOCATION	2-2	TROUBLESHOOTING	2-6
MAINTENANCE STANDARDS	2-3	HARNES ROUTING	2-7
TORQUE VALUES	2-4		

SERVICE INFORMATION

SYMBOLS USED IN THIS MANUAL

As you read this manual, you may find the following symbols with the instructions.



Apply grease.



A special tool is required to perform the procedure.



Apply oil.

○ x ○ (○): Indicates the diameter, length, and quantity of the metric flange bolt used.

P.○- ○: Indicates the reference page.

SERIAL NUMBER LOCATION

The engine serial number is stamped on the crankcase. Refer to this when ordering parts or making parts or making technical inquiries.

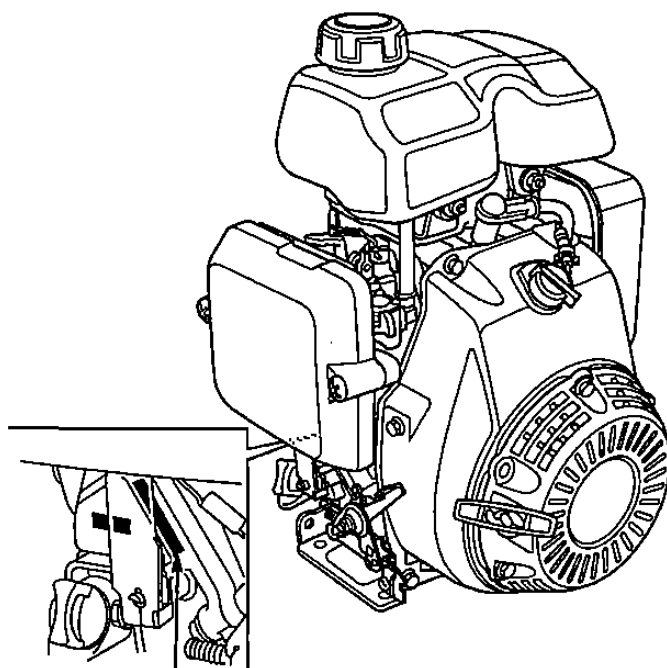

ENGINE SERIAL NUMBER

MAINTENANCE STANDARDS

Unit: mm (in)

Part	Item	Standard	Service limit
Engine	Maximum speed (No load)	4,000 ± 200 min ⁻¹ (rpm)	-
	Idle speed	1,550 ± 150 min ⁻¹ (rpm)	-
	Cylinder compression	0.49 MPa (5.0 kgf/cm ² , 71psi) at 700 min ⁻¹ (rpm)	-
Cylinder	Sleeve I.D.	56.000 - 56.015 (2.2047 - 2.2053)	56.165 (2.2112)
Piston	Skirt O.D.	55.965 - 55.985 (2.2033 - 2.2041)	55.85 (2.199)
	Piston-to-cylinder clearance	0.015 - 0.050 (0.006 - 0.0020)	0.120 (0.0047)
	Piston pin bore I.D.	13.002 - 13.008 (0.5119 - 0.5121)	13.048 (0.5137)
Piston pin	Piston pin O.D.	12.994 - 13.000 (0.5116 - 0.5118)	12.954 (0.5100)
	Piston-to-piston pin bore clearance	0.002 - 0.014 (0.0001 - 0.0006)	0.080 (0.0031)
Piston rings	Ring side clearance	Top/Second	0.120 (0.0047)
	Ring end gap	Top	0.15 - 0.30 (0.006 - 0.012)
		Second	0.30 - 0.45 (0.012 - 0.018)
	Ring width	Top	0.970 - 0.990 (0.0382 - 0.0390)
Second		1.170 - 1.190 (0.0461 - 0.0469)	
Connecting rod	Small end I.D.	13.005 - 13.020 (0.5120 - 0.5126)	13.070 (0.5146)
	Big end I.D.	24.000 - 24.013 (0.9449 - 0.9454)	24.040 (0.9465)
	Big end oil clearance	0.020 - 0.043 (0.0008 - 0.0017)	0.100 (0.0039)
	Big end axial clearance	0.1 - 0.4 (0.004 - 0.016 in)	0.800 (0.0315)
Crankshaft	Crank pin O.D.	23.970 - 23.980 (0.9437 - 0.9441)	23.920(0.9417)
Valves	Valve clearance	IN	0.15 ± 0.04
		EX	0.20 ± 0.04
	Stem O.D.	IN	3.970 - 3.985 (0.1563 - 0.1569)
		EX	3.935 - 3.985 (0.1549 - 0.1555)
Valve guides	Guide I.D.	IN/EX	4.000 - 4.018 (0.1575 - 0.1582)
	Stem-to-guide clearance	IN	0.015 - 0.048 (0.0006 - 0.0019)
		EX	0.050 - 0.083 (0.0020 - 0.0033)
	Seat width	IN/EX	0.7 (0.028)
Valve springs	Free length	IN/EX	25.8 (1.02)
Cam pulley	Cam height		36.483 (1.4363)
	Cam pulley I.D.(Bearing)		10.027 - 10.057 (0.3948 - 0.3959)
	Cam pulley shaft O.D.		9.972 - 9.987 (0.3926 - 0.3932)
Rocker arm	Rocker arm I.D.		6.000 - 6.018 (0.2362 - 0.2369)
	Rocker arm shaft O.D.		5.960 - 5.990 (0.2346 - 0.2358)
	Rocker arm shaft bearing I.D.		6.000 - 6.018 (0.2362 - 0.2369)
Carburetor	Main jet		#60
	Pilot jet		#35
	Float height		12(0.5)
	Pilot screw opening		2 - 3/8 turns out
Spark plug	Gap		0.6 - 0.7 (0.024 - 0.028)
Ignition coil	Resistance	Primary coil	0.75 - 0.95Ω
		Secondary coil	6.1 - 9.3 Ω
	Air gap	(At flywheel)	0.2 - 0.5 mm (0.008 - 0.020 in)

SERVICE INFORMATION

TORQUE VALUES

Item	Thread dia. (mm)	Torque		
		N·m	kgf·m	lbf·ft
Spark plug	M10 x 1.0	12	1.2	9
Connecting rod bolt	M5 x 0.8	5	0.5	3.6
Oil drain plug bolt	M10 x 1.25	18	1.8	13
Valve adjusting lock nut	M5 x 0.5 (Special nut)	7.5	0.75	5.4
Flywheel nut	M12 x 1.25	42	4.3	31
Governor arm nut	M6 x 1.0	10	1.0	7
Stopper plate screw	M3 x 0.5	1	0.1	0.7
Air cleaner case bolt	M5 x 0.8	7	0.7	5.1
Air cleaner cover bolt	M6 x 1.0	2.3	0.23	1.7

NOTE:

- Use standard torque values for fasteners that are not listed in this table.
- (CT) indicates a self-tapping bolt.
- (SH) indicates a small head bolt.

STANDARD TORQUE VALUE

Item	Thread dia. (mm)	Torque		
		N·m	kgf·m	lbf·ft
Screw	5 mm	4.3	0.43	3.1
	6 mm	9	0.9	6.5
Bolt and nut	5 mm	5	0.5	3.6
	6 mm	10	1.0	7
	8 mm	21	2.1	15
	10 mm	34	3.5	25
	12 mm	54	5.5	40
Flange bolt and nut	5 mm	5.5	0.55	4.0
	6 mm	12	1.2	9
	8 mm	26	2.7	20
	10 mm	39	4.0	29
SH flange bolt	6 mm	9	0.9	6.5
CT flange bolt	5 mm	5.5	0.55	4.0
	6 mm	12	1.2	9

SPECIAL TOOLS

No.	Tool name	Tool number	Application
1.	Float level gauge	07401 - 0010000	Carburetor float level inspection
2.	Driver, 22 mm I.D.	07746 - 0020100	Driver for 5
3.	Attachment, 32 x 35 mm	07746 - 0010100	20 x 32 x 6 mm oil seal installation
4.	Attachment, 42 x 47 mm	07746 - 0010300	6204 radial ball bearing installation
5.	Attachment, 20 mm I.D.	07746 - 0020400	6204 radial ball bearing installation
6.	Pilot, 20 mm	07746 - 0040500	20 x 32 x 6 mm oil seal and 6204 radial ball bearing installation
7.	Driver	07749 - 0010000	Driver for 3,4, and 6
8.	Valve seat cutter, 45° 24.5 mm(*1)	07780 - 0010100	Valve seat reconditioning (IN)
9.	Valve seat cutter, 45° 24 mm(*1)	07780 - 0010600	Valve seat reconditioning (EX)
10.	Valve seat cutter, 32° 25 mm(*1)	07780 - 0012000	Valve seat reconditioning (IN)
11.	Valve seat cutter, 32° 24 mm(*1)	07780 - 0012500	Valve seat reconditioning (EX)
12.	Valve seat cutter, 60° 24 mm(*1)	070PH - Z0D0100	Valve seat reconditioning (IN/EX)
13.	Cutter holder, 4.0 x 400 mm(*1)	070PH - Z0D0200	Holder for 8,9,10,11 and 12
14.	Valve adjusting wrench, 3mm	07908 - KE90200	Valve clearance adjustment
15.	Valve guide driver, 3.6 x 8.0 mm	07JMD - KY20100	Valve guide removal/installation
16.	Valve guide reamer, 4.008 mm	07MMH - MV90100	Valve guide I.D. reaming

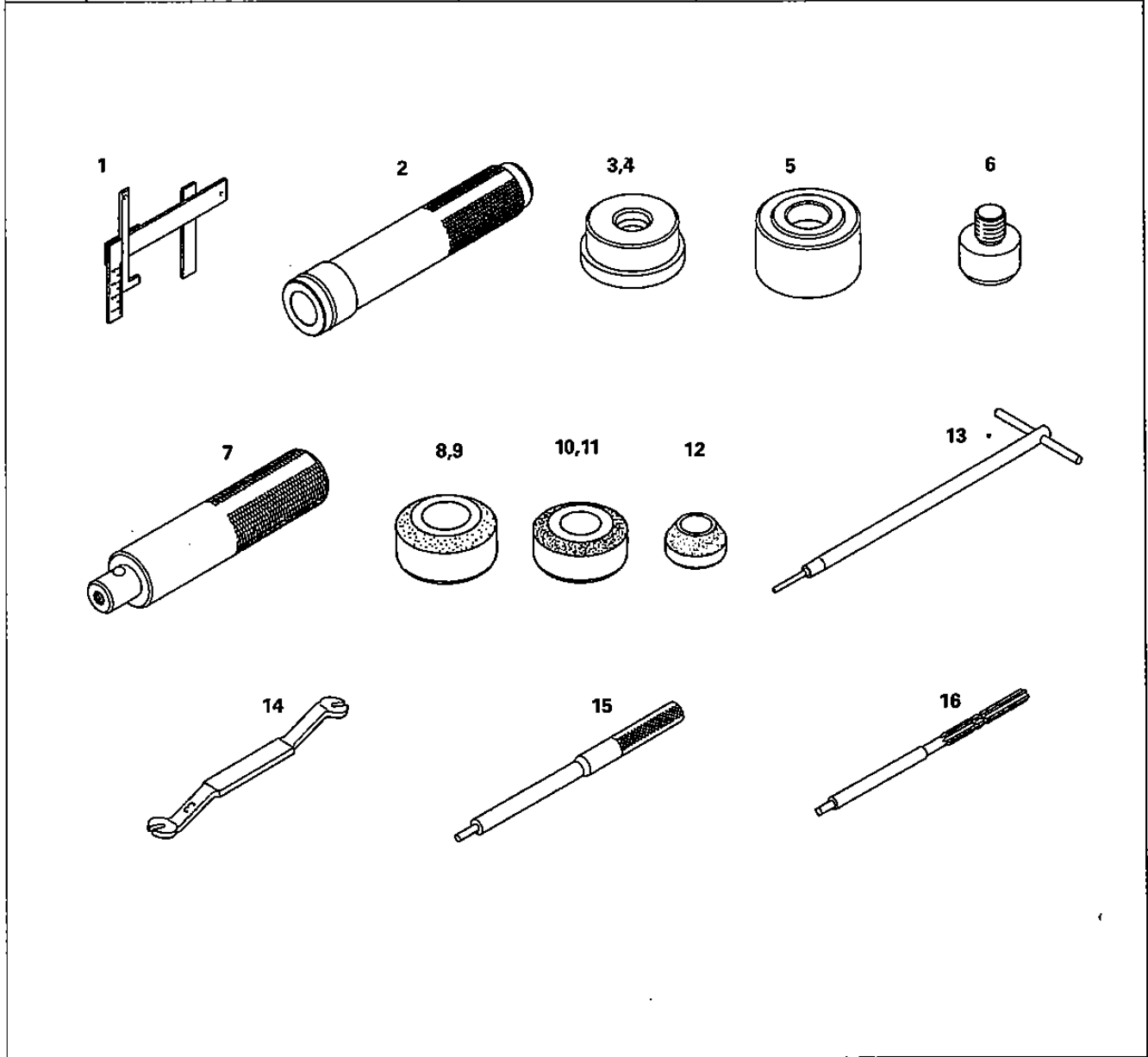

SERVICE INFORMATION

TROUBLESHOOTING

GENERAL SYMPTOMS AND POSSIBLE CAUSES

ENGINE

Hard starting

Cylinder compression check

1. Remove the spark plug cap and spark plug, and install a compression gauge in the spark plug hole.
2. Pull the recoil starter several times with force and measure the cylinder compression.

Cylinder compression 0.49 Mpa (5.0 kgf/cm², 71 psi)
at 700 min⁻¹ (rpm)

COMPRESSION GAUGE
(Commercially available)

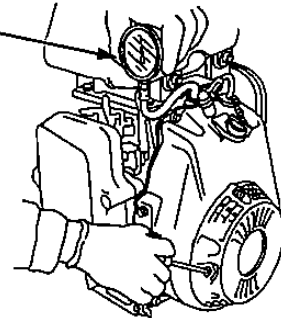

Engine starts but then stalls

Engine lacks power

Engine speed does not increase

OIL ALERT SYSTEM (TYPE WITH OIL ALERT)

Engine does not start with engine stop switch "ON"

- Check the engine oil level before inspection. There must be sufficient oil in the tank.

Engine does not stop while engine oil level is low

- Drain the engine oil before inspection.

IGNITION SYSTEM

Spark test

⚠ WARNING

Gasoline is highly flammable and explosive. If ignited, gasoline can burn you severely.

- Be sure there is no spilled fuel near the engine.
- Place the spark plug away from the spark plug hole.

Unburnt gas can ignite if it is left in the cylinder.

- Loosen the carburetor drain screw to drain the carburetor thoroughly. Pull the recoil starter several times to release the unburnt gas from the cylinder before testing.

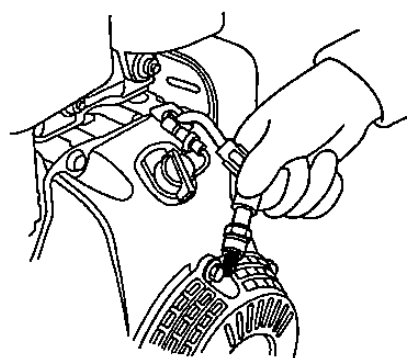

1. Remove the spark plug cap and spark plug.
2. Turn the fuel valve OFF and drain the carburetor by loosening the drain screw. Then pull the recoil starter several times to release the unburnt gas in the cylinder with the engine stop switch OFF.
3. Attach the removed spark plug to the plug cap.
4. Set the engine stop switch to the "ON" position. Ground the negative (-) electrode (i.e. threaded part) of the spark plug against the recoil starter mounting nut and pull the recoil starter to check whether spark jump across the electrodes.

HARNESS ROUTING

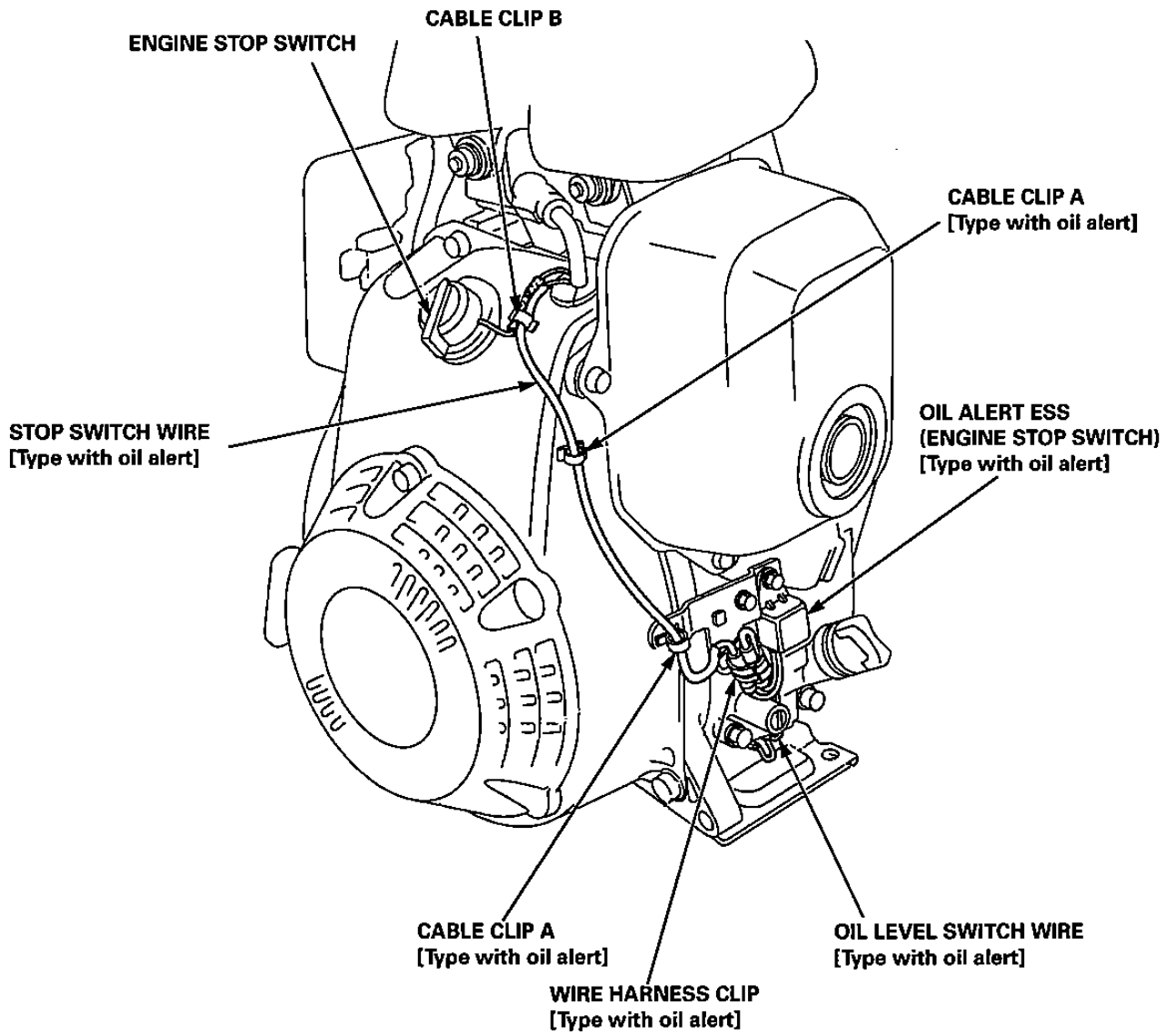

SERVICE INFORMATION

3. MAINTENANCE



MAINTENANCE SCHEDULE.....	3-2	VALVE CLEARANCE	3-7
OIL ALERT(TYPE WITH OIL ALERT).....	3-2	CARBURETOR	3-8
ENGINE OIL.....	3-3	GOVERNOR	3-9
AIR CLEANER.....	3-5	FUEL FILTER/FUEL TANK/FUEL TUBE	3-10
SPARK PLUG	3-6	SPARK ARRESTER (OPTIONAL PARTS).....	3-11

MAINTENANCE

MAINTENANCE SCHEDULE

REGULAR SERVICE PERIOD(1)									
ITEM			Each use	First month or 20 Hrs.	Every 3 months or 50 Hrs.	Every 6 months or 100 Hrs.	Every year or 200 Hrs.	Refer to page	
●	Engine oil	Check level	○					3-21	
		Change		○		○			
●	Air cleaner	Check	○					3-41	
		Clean			○(2)				
		Replace					○		
●	Spark plug	Check – Clean				○		3-51	
		Replace					○		
	Spark arrester (Optional part)	Clean				○		3-91	
●	Idle speed	Check – Adjust					○	3-71	
●	Combustion chamber	Clean	After every 300 Hrs.						9-131
●	Valve clearance	Check – Readjust					○	3-51	
●	Fuel tank & filter	Clean				○		3-81	
●	Fuel line	Check	Every 2 years(Replace if necessary)						3-81

● Emission related items.

1. For commercial use, log hours of operation to determine proper maintenance intervals.
2. Service more frequently when used in dusty areas.

OIL ALERT(TYPE WITH OIL ALERT)

For convenience, perform this test in conjunction with the engine oil change.

1. With the engine running, disconnect the yellow connector from the oil alert ESS and ground against the engine. The oil alert ESS is normal if the engine stops.
2. Drain the oil from the engine and reconnect the yellow connector.
3. Remove the spark plug and perform spark test (page 2-6). There should be no spark.

Perform the troubleshooting "OIL ALERT SYSTEM on page 2-6 and IGNITION SYSTEM on page 2-6", if abnormal.

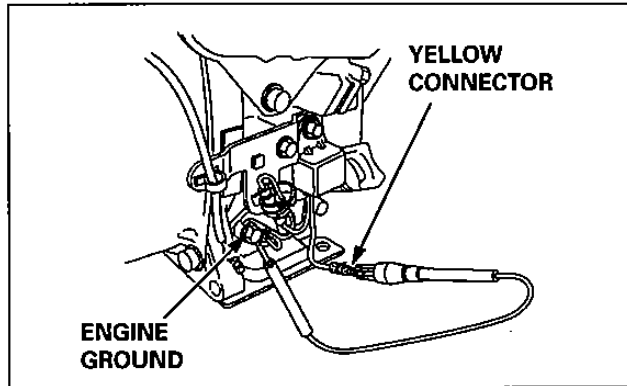

ENGINE OIL

OIL LEVEL CHECK:

Check the engine oil level with the engine stopped and the engine on a level surface.

1. Remove the oil filter cap/dipstick and wipe it clean.
2. Insert the dipstick without screwing it into the oil filter neck.
Remove the dipstick and check the oil level. If the oil does not stick on the dipstick, the oil level is low.

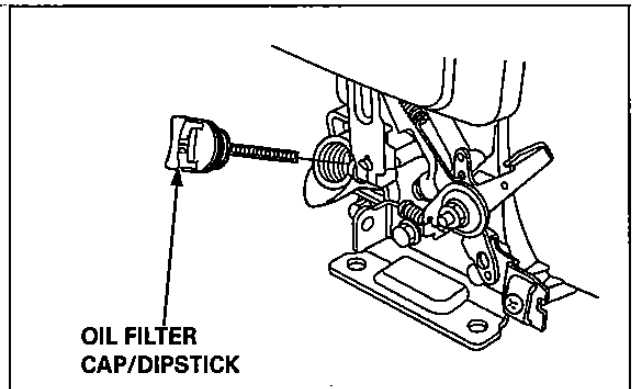

3. If the oil level is low, fill to the edge of the oil filter neck with the recommended oil. Do not overfill.

Change the oil if it is stale or contaminated with foreign material.

Recommended oil **SAE 10W-30 or SAE 30**
 API Service Classification SJ minimum

Oil is a major factor affecting performance and service life. Use 4-stroke automotive detergent oil.

SAE 10W-30 is recommended for general use. Other viscosities shown in the chart may be used when the average temperature in your area is within the recommended range.

Recommended operating ambient temperature oil **-15 °C – 40 °C (5 °F – 104 °F)**

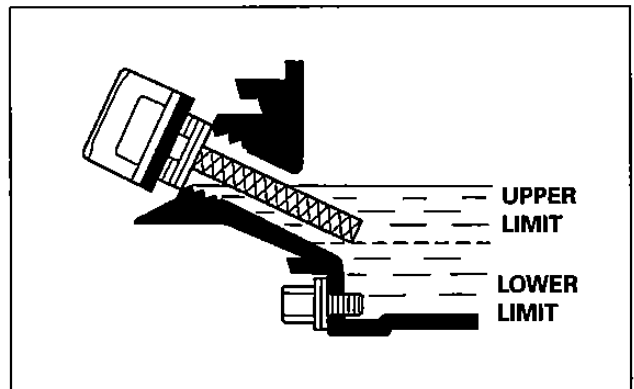

4. Install the oil filler cap/dipstick securely.

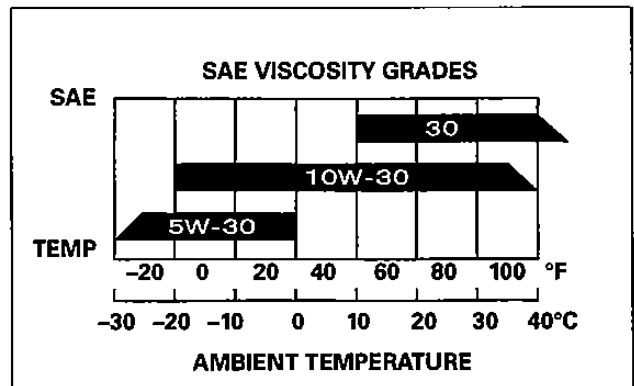

MAINTENANCE

OIL CHANGE:

Drain the used oil while the engine is warm. Warm oil drains quickly and completely.

1. Remove the oil filler cap/dipstick and oil drain bolt, and drain the oil into a suitable container.

Please dispose of the used motor oil in a manner that is compatible with the environment. We suggest you take used oil in a sealed container to your local recycling center or service station for reclamation. Do not throw it in the trash, pour it on the ground, or down a drain.

⚠ CAUTION

- Used engine oil contains substances that have been identified as carcinogenic.
- If repeatedly left in contact with the skin for prolonged periods, it may cause skin cancer.
- Wash your hands thoroughly with soap and water as soon as possible after contact with used engine oil.

2. Install a new sealing washer and oil drain bolt and tighten the bolt to the specified torque.

TORQUE: 1.8 N·m (1.8 kgf·m, 13 lbf·ft)

3. With the engine on a level surface, refill with the recommended fresh engine oil to the specified level.

Engine oil capacity 0.40 liters (0.42 US qt, 0.35 Imp qt)

4. Check the oil level again and add to the lower edge of the oil filler neck if necessary.

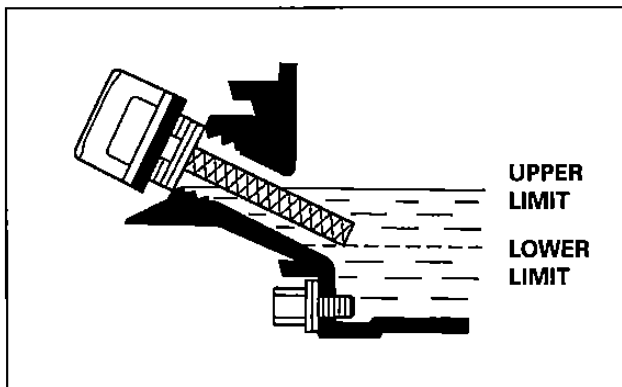
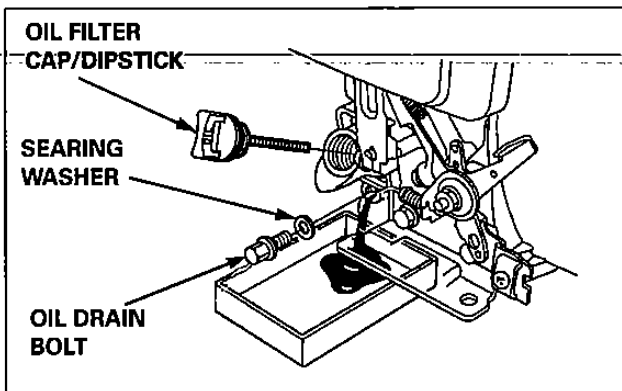

AIR CLEANER

A dirty air filter will restrict air flow to the carburetor, reducing engine performance. If the engine is operated in dusty areas, clean the air filter more often than specified in the MAINTENANCE SCHEDULE.

NOTICE

Operating the engine without an air filter or with a damaged air filter, will allow dirt to enter the engine, causing rapid engine wear. This type of damage is not covered by the Distributor's Limited Warranty.

CLEANING:

1. Remove the air cleaner cover bolts and air cleaner cover.
2. Remove the paper element from the air cleaner case.
Remove the foam element from the air cleaner cover.
3. Check both air cleaner elements for holes or tears and replace if damaged.

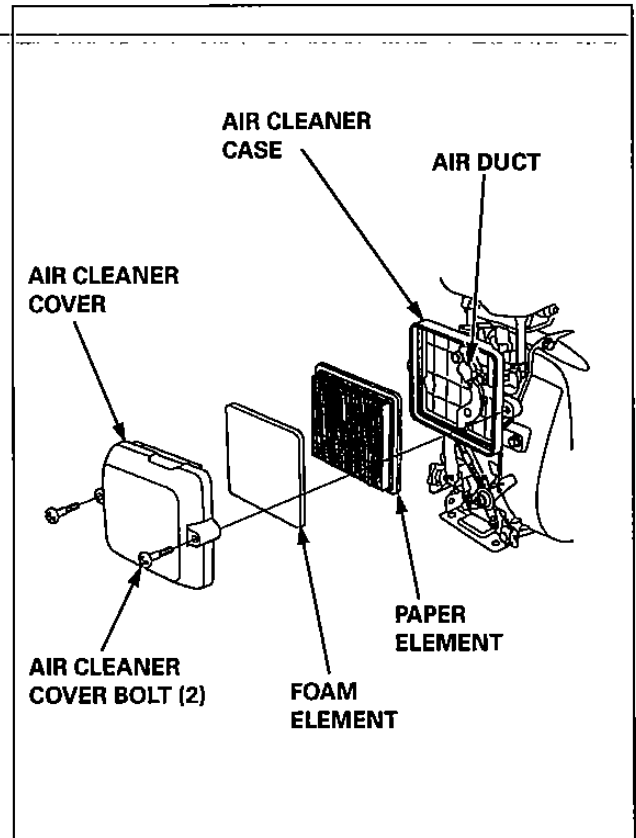

4. Clean both air cleaner elements if they are to be reused.

Foam element: Clean in warm soapy water, rinse and allow to dry thoroughly. Or clean in nonflammable solvent and allow to dry. Do not put oil to the foam element.

Paper element: Tap the element several times on a hard surface to remove dirt, or blow with compressed air [not exceeding 30 psi (207 kPa, 2.1 kgf/cm²)] through the element from the clean side that faces the engine. Never try to brush off dirt. Brushing will force dirt into the fibers.

5. Wipe from the inside of the air cleaner case and cover, using a moist rag. Be careful to prevent dirt from entering the air duct that leads to the carburetor.
6. Place the foam element to the air cleaner cover. Reinstall the paper element and the air cleaner cover to the air cleaner case.
7. Install the air cleaner cover and tighten the air cleaner cover bolts to the specified torque.

TORQUE: 2.3 N·m (0.23 kgf·m, 1.7 lbf·ft)

FOAM ELEMENT

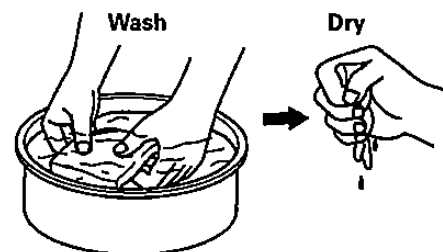

In cleaning solvent or warm soapy water.

PAPER ELEMENT

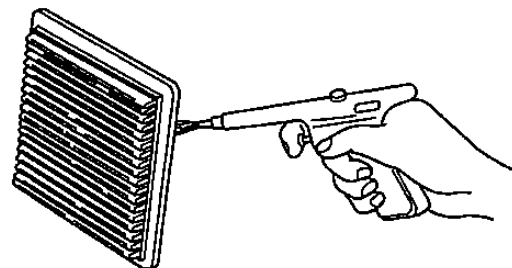

MAINTENANCE

SPARK PLUG

INSPECTION/CLEANING

If the engine has been running, the engine will be very hot. Allow it to cool before proceeding.

1. Clean any dirt from around the spark plug.
2. Remove the spark plug cap, and remove the spark plug using a plug wrench.

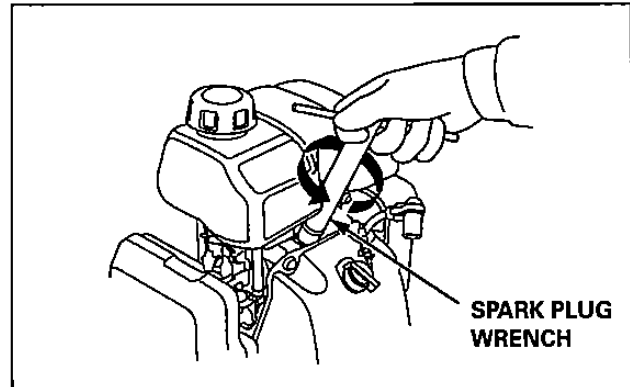

3. Visually inspect the spark plug.
4. Replace the plug if the electrodes are worn, the insulator is cracked or chipped, or the plug is fouled.

Check the sealing washer for damage.

5. Measure the plug gap with a wire-type feeler gauge. If the measurement is out of the specification, adjust by bending the side electrode.

Spark plug gap 0.6 – 0.7 mm (0.024 – 0.028 in)

Recommended spark plug CR5HSB (NGK)
U15FSR – UB(DENSO)

6. Install the spark plug fingertight to seat the washer, then tighten with a plug wrench.
 - If reinstalling the used spark plug, tighten 1/8 – 1/4 turn after the spark plug seats.
 - If installing a new spark plug, tighten 1/2 turn after the spark plug seats.

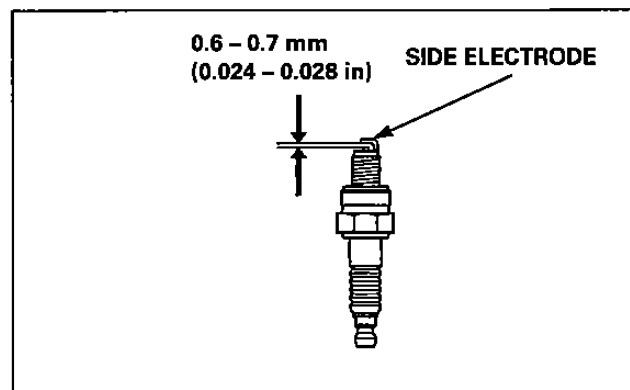

NOTICE

A loose spark plug can become very hot and can damage the engine. Overtightening the spark plug can damage the threads in the cylinder.

7. Install the spark plug cap.

VALVE CLEARANCE

Valve clearance inspection and adjustment must be performed with the engine cold.

CHECK:

1. Remove the fuel tank (page 4-2)
2. Loosen the four 6 x 14 mm flange bolts, and remove the fuel tank stay A and B.

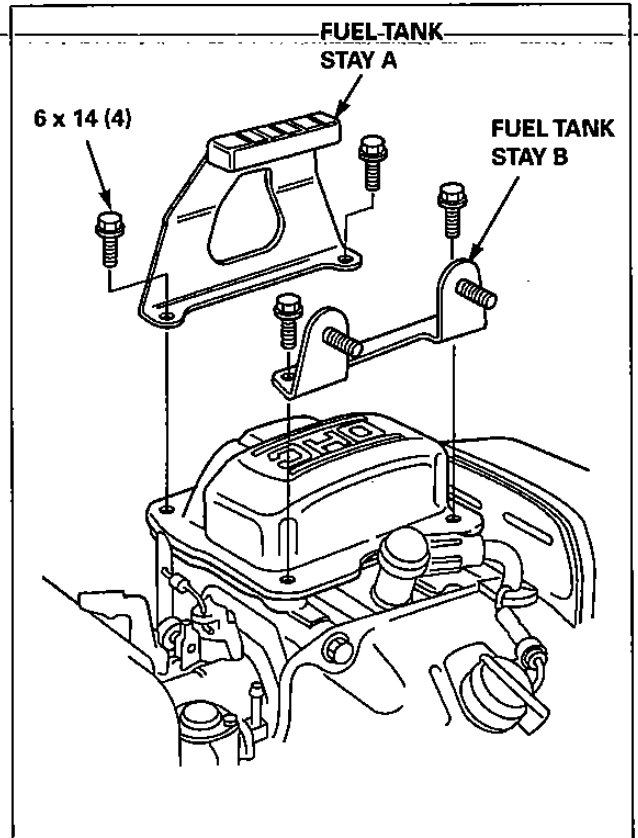

3. To remove the head cover, insert a screw driver or equivalent tool into the recess in the position of the cylinder shown. Remove the head cover slowly.
 - Clean up any spilled engine oil with a shop towel when removing the head cover.

NOTICE

- Do not remove the head cover with force, because that can deform the head cover.
- Replace the head cover if it is deformed.

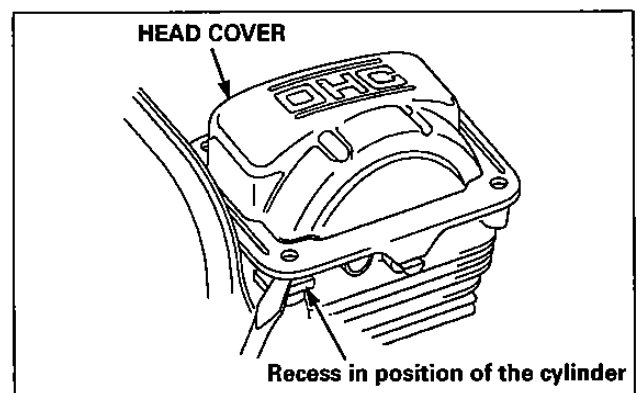

4. Remove the recoil starter (page 7-2)
5. Set the piston top dead center of the compression stroke (both valves fully closed). Align the cutout in the flywheel fin or the alignment mark on the flywheel with the top hole on the fan cover, turn the flywheel one turn and align the marks.
 - If the exhaust valve opens when the cutout in the flywheel fin is aligned with the top hole on the fan cover, turn the flywheel one turn and align the marks.

The top dead center of the compression stroke is in the position where the head cover mating surface is in line with the cam pulley alignment marks.

6. Insert a feeler gauge between the valve adjusting screw and the valve and measure the valve clearance.

Valve clearance	.IN	0.15 ± 0.04 mm
	EX	0.20 ± 0.04 mm

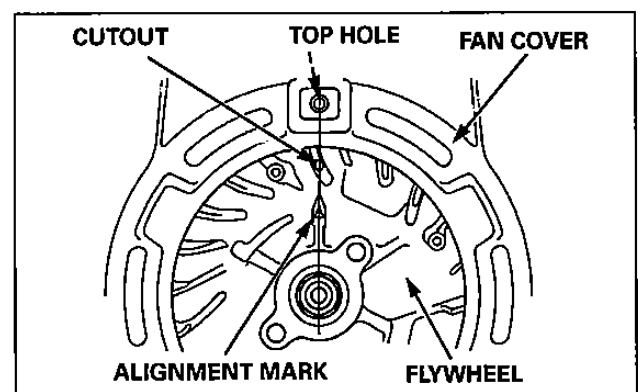

MAINTENANCE

ADJUSTMENT:

1. If adjustment is necessary, proceed as follows.

1. ~~Hold the valve adjusting screw using the special tool, and loosen the lock nut.~~

TOOL:

Valve adjuster wrench, 3mm 07908-KE90200

2. Turn the adjusting screw to obtain the specified intake and exhaust valve clearance.

3. Hold the valve adjusting screw using the special tool, and tighten the lock nut.

TORQUE: 7.5 N·m (0.75 kgf·m, 5.4 lbf·ft)

2. Recheck valve clearance after tightening the lock nut.

3. Install the head cover (page 9-3) and recoil starter (page 7-2).

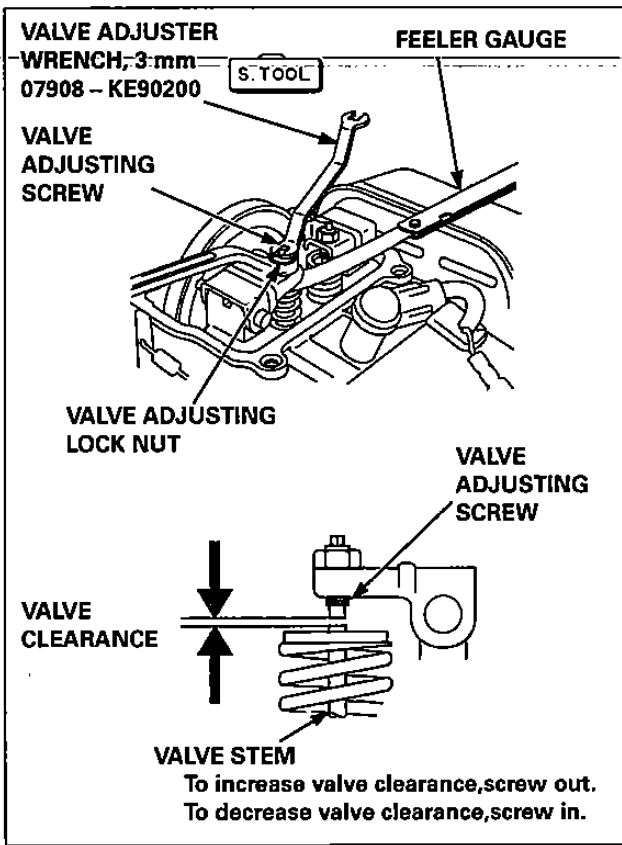

CARBURETOR

PILOT SCREW:

The pilot screw is fitted with a limiter cap that prevents excessive enrichment of the air-fuel mixture in order to comply with emissions regulations.

Do not attempt to remove the limiter cap for pilot screw adjustment. The limiter cap cannot be removed without breaking the pilot screw.

Pilot screw adjustment must be performed only when the carburetor is disassembled and the pilot screw is replaced (page 4-8)

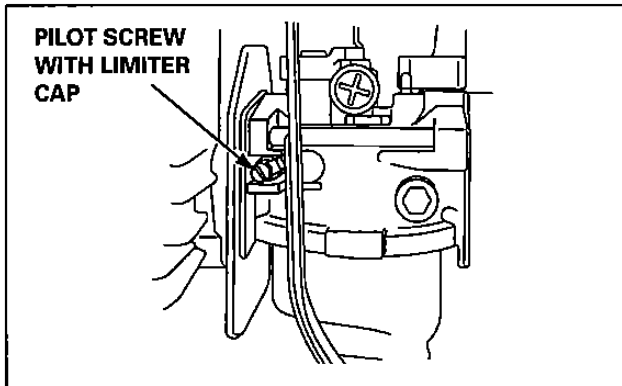

IDLE SPEED ADJUSTMENT

1. Start the engine and allow it to warm up to normal operating temperature.
2. With the engine idling, turn the throttle stop screw to obtain the standard idle speed.

Standard idle speed 1,550 ±150 mm⁻¹ (rpm)

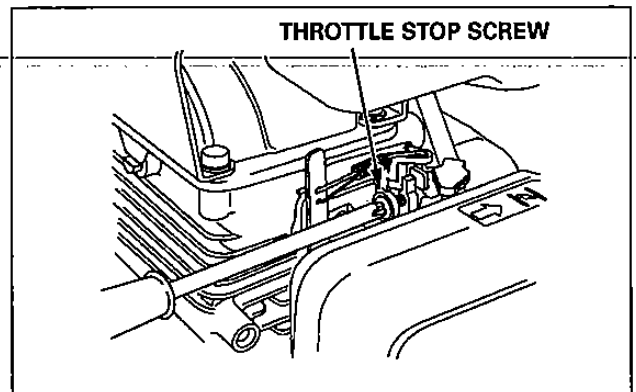

GOVERNOR ADJUSTMENT

1. Move the control lever to the "FAST" position.
2. Loosen the governor arm nut on the governor arm.
3. Push the governor arm end toward the carburetor side, open the carburetor throttle valve fully.
4. Holding the carburetor throttle valve fully opened, turn the governor arm shaft clockwise fully, and tighten the governor arm nut to the specified torque.

TORQUE: 10 N·m (1.0 kgf·m, 7 lbf·ft)

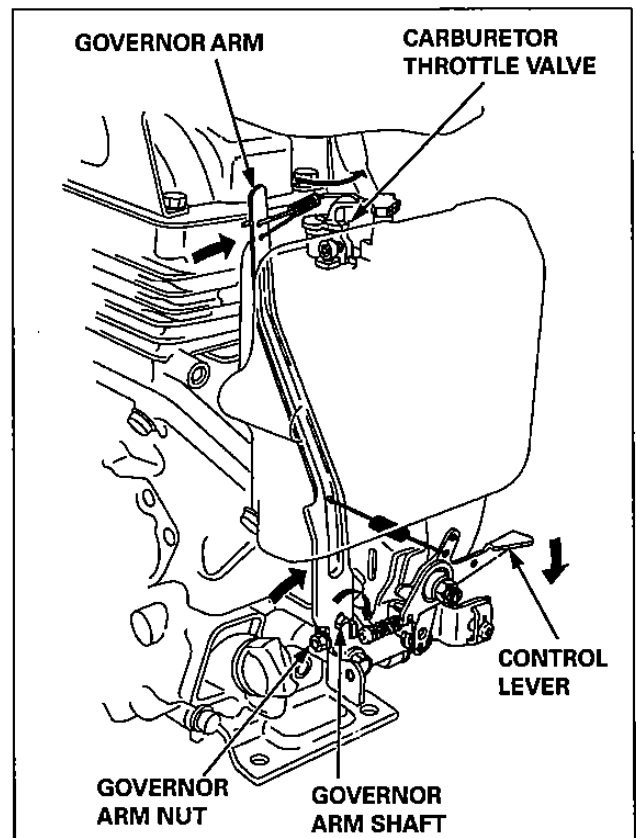

5. Check to see whether the governor arm and the carburetor throttle valve operate smoothly.
6. Start the engine and allow it to warm up to the normal operating temperature.

Move the control lever to the maximum engine speed position and check the maximum engine speed.

Maximum engine speed (no load) 4,000 ± 200 mm⁻¹ (rpm)

7. Adjust the maximum engine speed, if necessary, by turning the adjusting screw in or out.

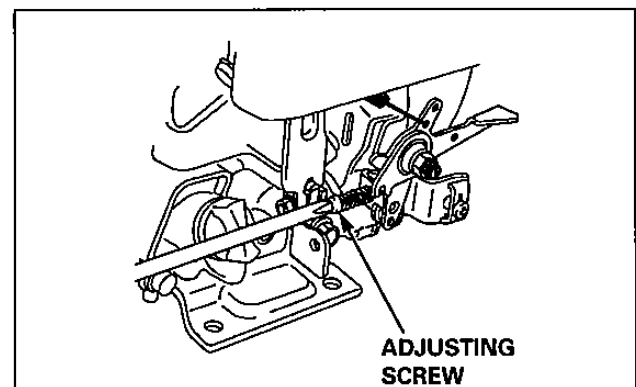

MAINTENANCE

FUEL FILTER/FUEL TANK/FUEL TUBE

CLEANING:

⚠ WARNING

Gasoline is highly flammable and explosive. You can be burned or seriously injured when handling fuel.

- Keep heat, sparks, and flame away.
- Handle fuel only outdoors.
- Wipe up spills immediately.

1. Drain the fuel into a suitable container, and remove the fuel tank.
2. Disconnect the fuel tube, and unscrew the fuel filter from the fuel tank.
3. Clean the filter with solvent, and check to be sure the filter screen is undamaged.
4. Clean the fuel tank with solvent, and allow the fuel tank to dry thoroughly.
5. Check the fuel tube for deterioration, cracks or signs of leakage.
6. After cleaning, set the fuel filter in the fuel tank and connect the fuel tube.
7. Install the fuel tank and check for fuel leakage from the fuel tube.

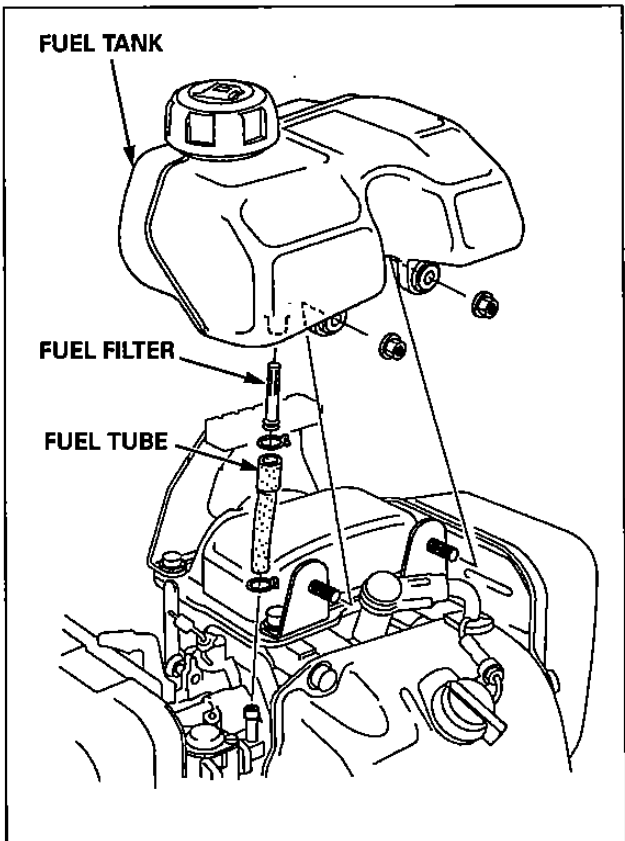

SPARK ARRESTER (OPTIONAL PARTS)

CLEANING:

⚠ CAUTION

The engine and muffler become very hot during operation and they remain hot for a while after operation. Be sure that the engine is cool before muffler removal/installation.

1. Remove the three 6 x 12 mm flange bolts from the muffler protector.
2. Remove the 4 x 6 mm tapping screw from the spark arrester, and remove the spark arrester from the muffler.

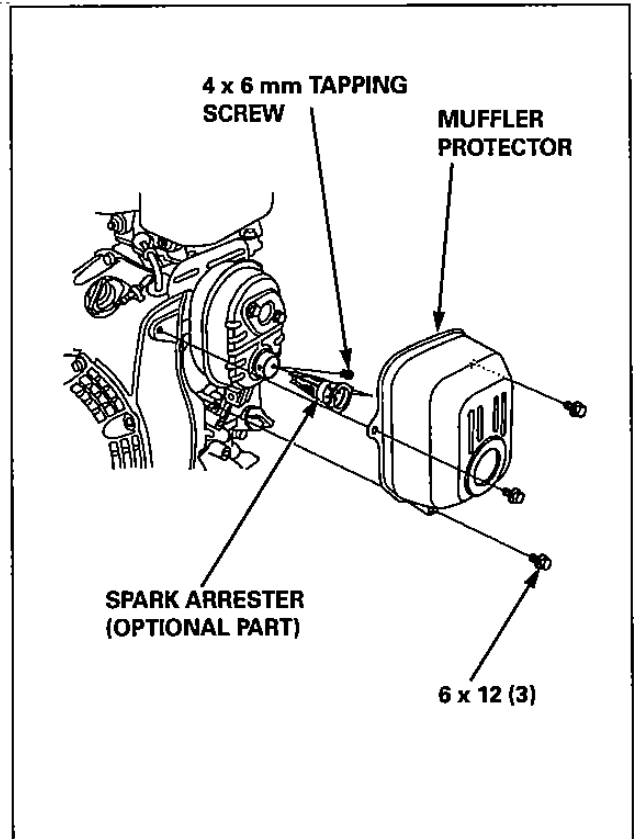

3. Check for carbon deposits around the exhaust port and spark arrester. Clean, if necessary, with a wire brush.
4. Replace the spark arrester if there are any breaks or tears.
5. Install the spark arrester and muffler protector in the reverse order of removal.

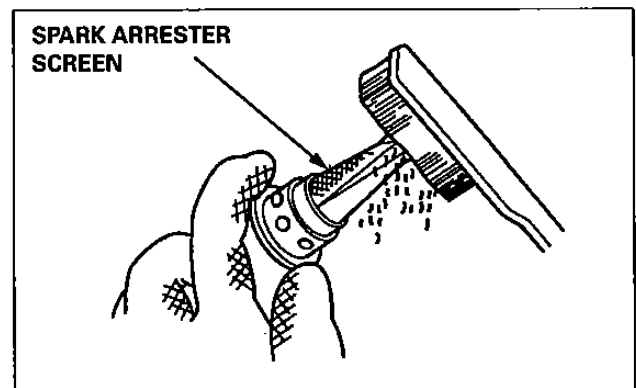

MAINTENANCE

4. FUEL SYSTEM



FUEL TANK	4-2	CARBURETOR	4-6
AIR CLEANER.....	4-4		

FUEL SYSTEM

FUEL TANK

REMOVAL/INSTALLATION

⚠ WARNING

Gasoline is highly flammable and explosive. You can be burned or seriously injured when handling fuel.

- Keep heat, sparks, and flame away.
- Handle fuel only outdoors.
- Wipe up spills immediately.
- Drain the fuel tank thoroughly before removal.

Fuel tank:

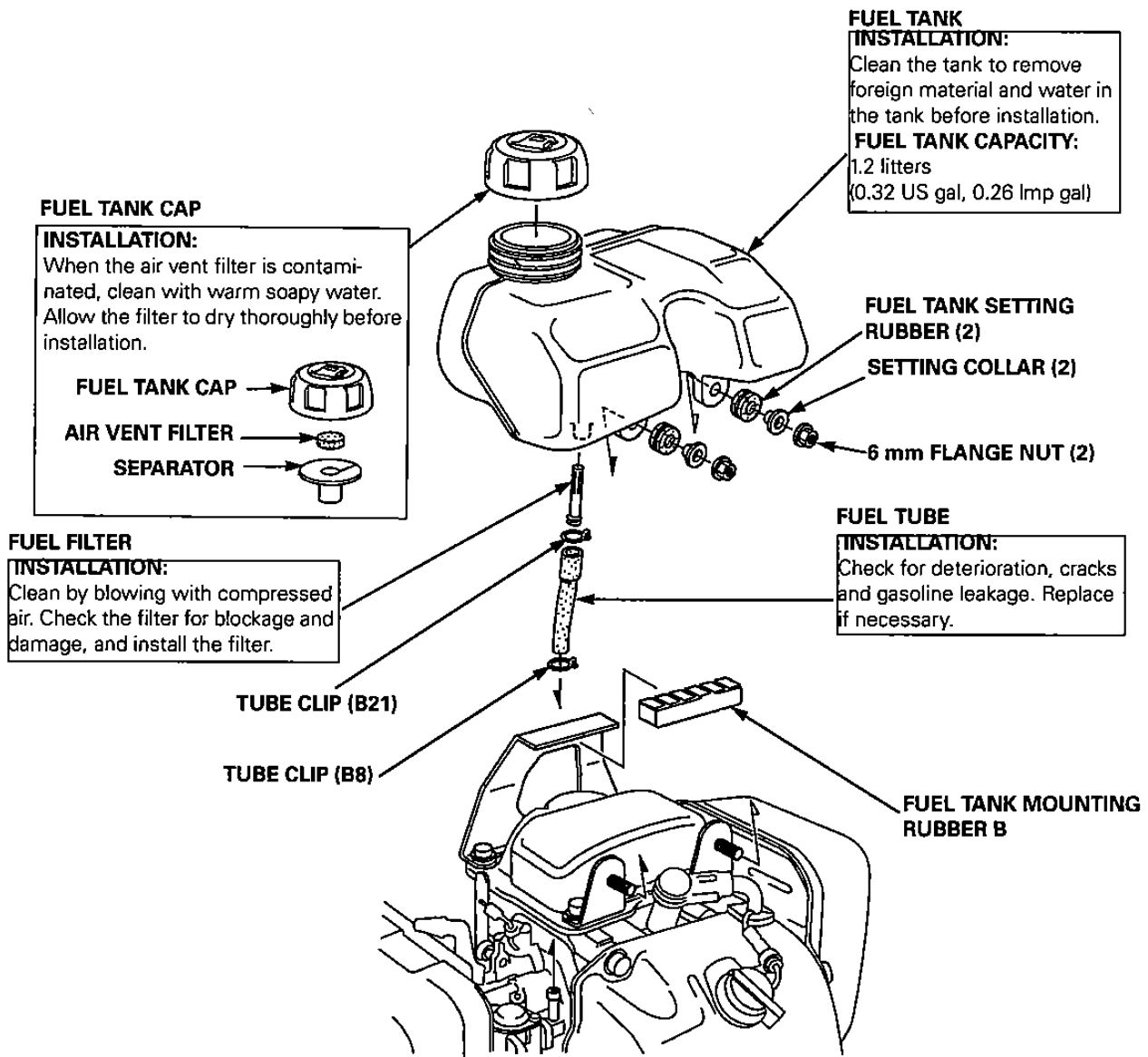

Fuel tank stay A/B:

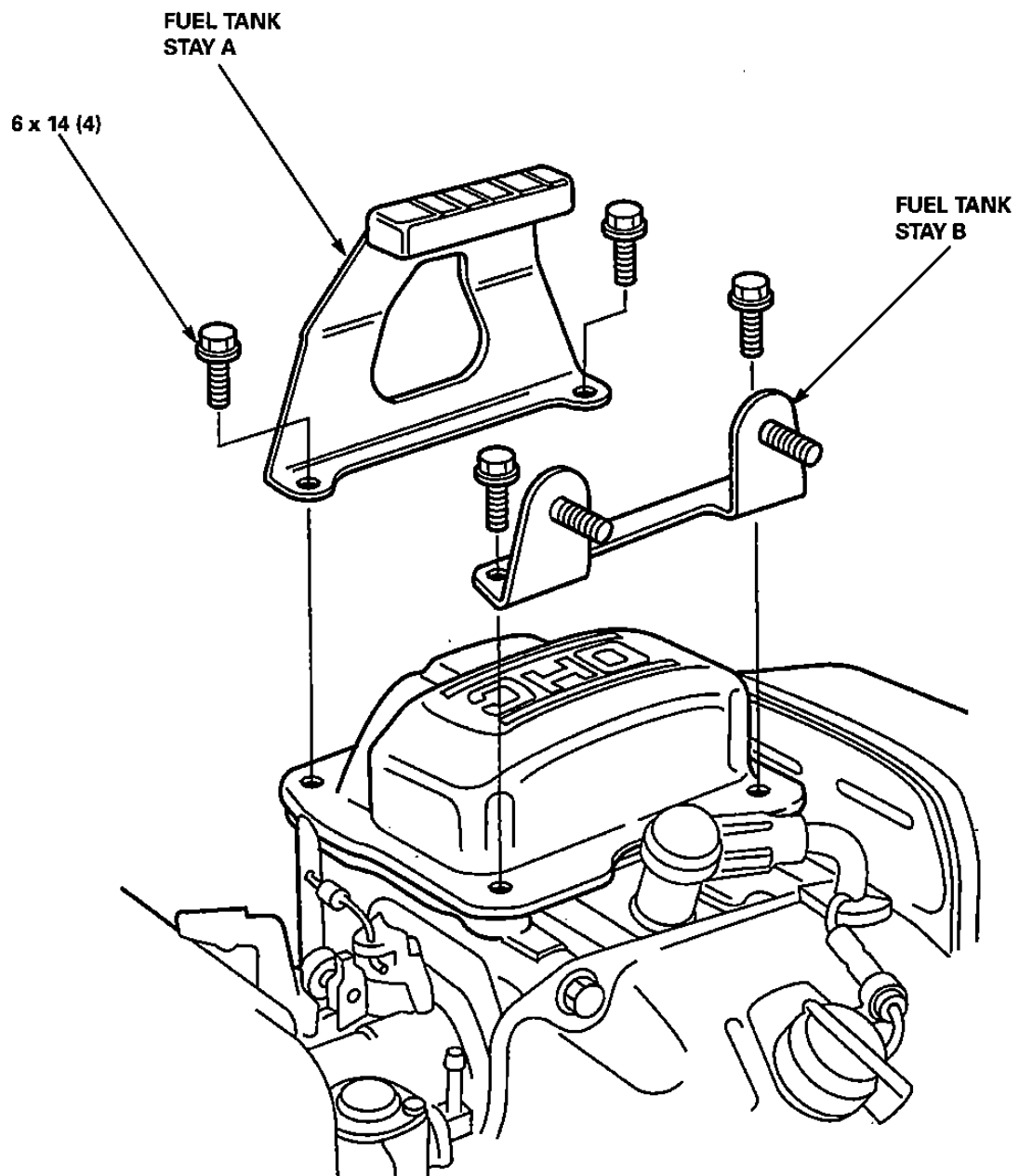

FUEL SYSTEM

AIR CLEANER

REMOVAL/INSTALLATION

Before removal, completely drain the fuel line.

⚠ WARNING

Gasoline is highly flammable and explosive. You can be burned or seriously injured when handling fuel.

- Keep heat, sparks, and flame away.
- Handle fuel only outdoors.
- Wipe up spills immediately.

NOTICE

If the air cleaner removal/installation is made with the carburetor installed, hand tighten the 5 x 77 mm flange bolts. Turn the choke lever to fully closed position to prevent dust and dirt from entering the engine.

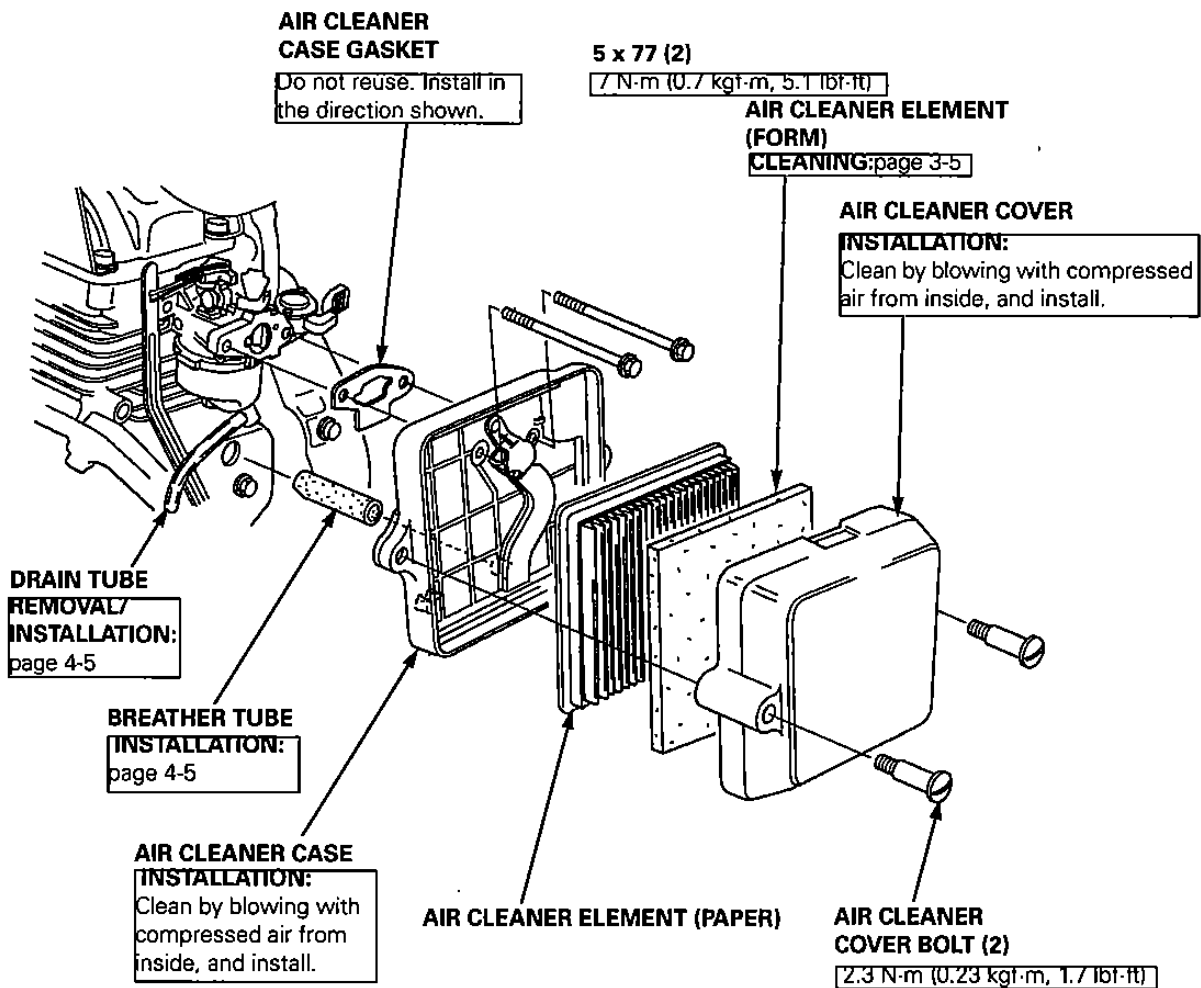

Drain tube removal:

Release the drain tube from the clamp at the back side of the air cleaner case.

Drain tube installation:

Set the drain tube securely in the clamp at the back side of the air cleaner case.

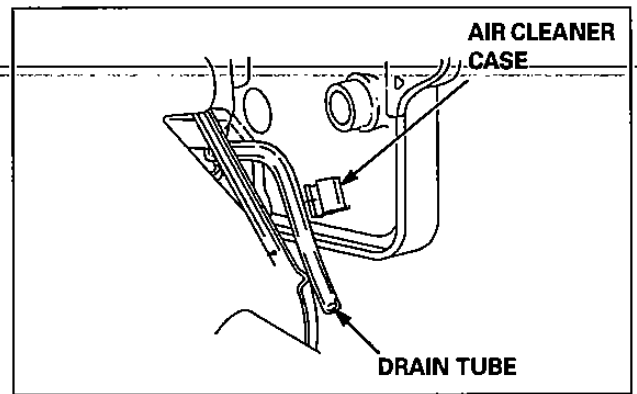

Breather tube installation:

Connect the breather tube to the cylinder barrel with the chamfer facing down as shown.

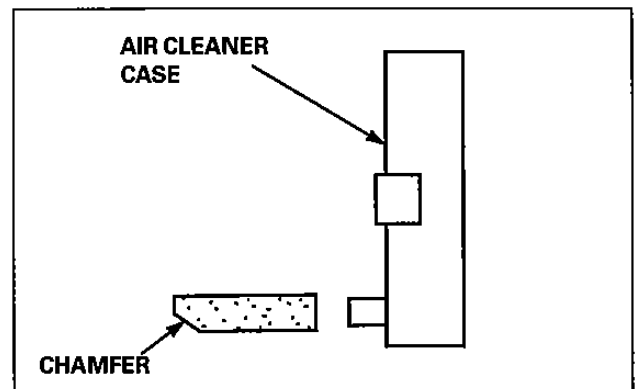

FUEL SYSTEM

CARBURETOR

REMOVAL/INSTALLATION

⚠ WARNING

Gasoline is highly flammable and explosive. You can be burned or seriously injured when handling fuel.

- Keep heat, sparks, and flame away.
- Handle fuel only outdoors.
- Wipe up spills immediately.

Before removal, completely drain the fuel line.

NOTICE

- Cover the intake port with clean tape or film to prevent dirt from entering into the engine.
- If these parts are left out, dirt will enter the intake system.

1. Disconnect the fuel tube (page 4-2)
2. Remove the two 5 x 77 mm flange bolts, and remove the governor rod and the throttle return spring from the carburetor throttle lever.

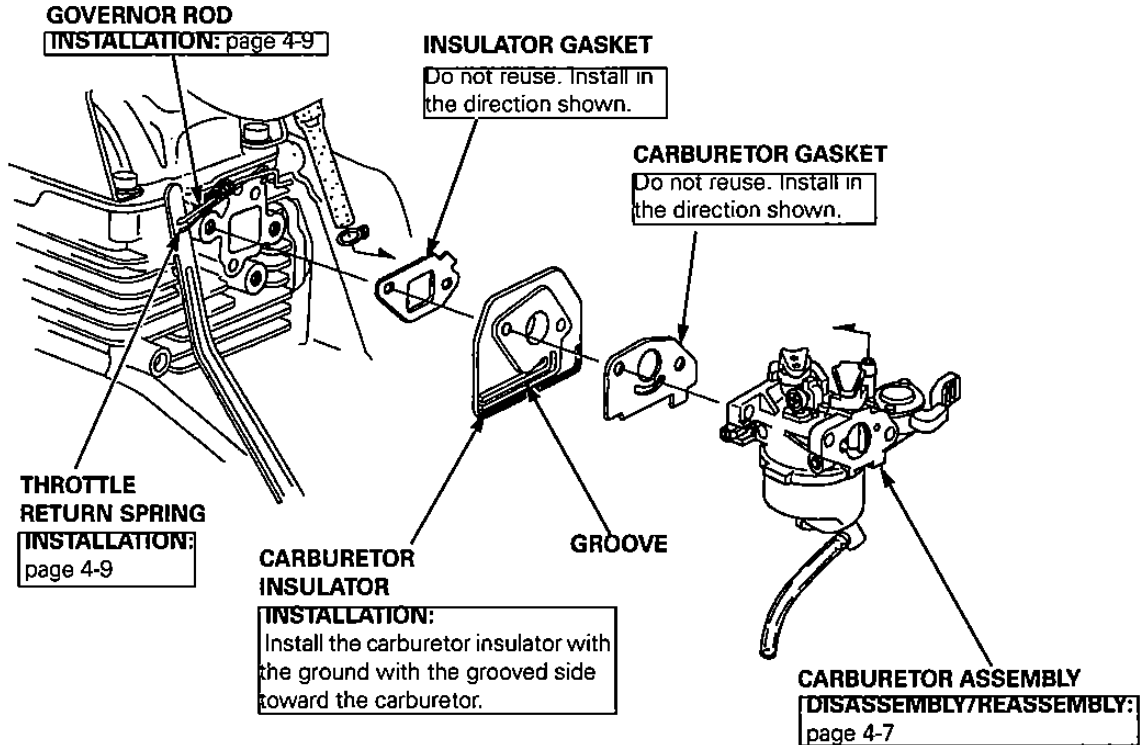
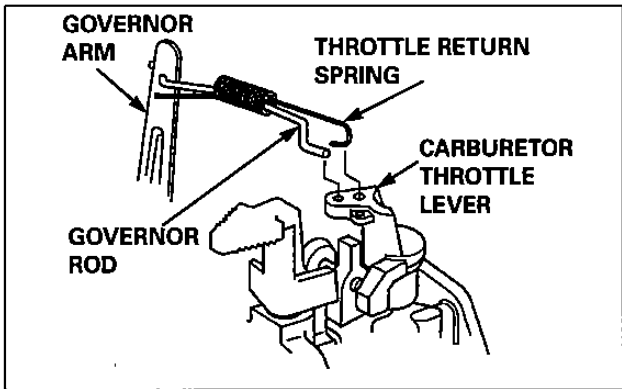

DISASSEMBLY/REASSEMBLY

⚠ WARNING

Gasoline is highly flammable and explosive. You can be burned or seriously injured when handling fuel.

- Keep heat, sparks, and flame away.
- Handle fuel only outdoors.
- Wipe up spills immediately.

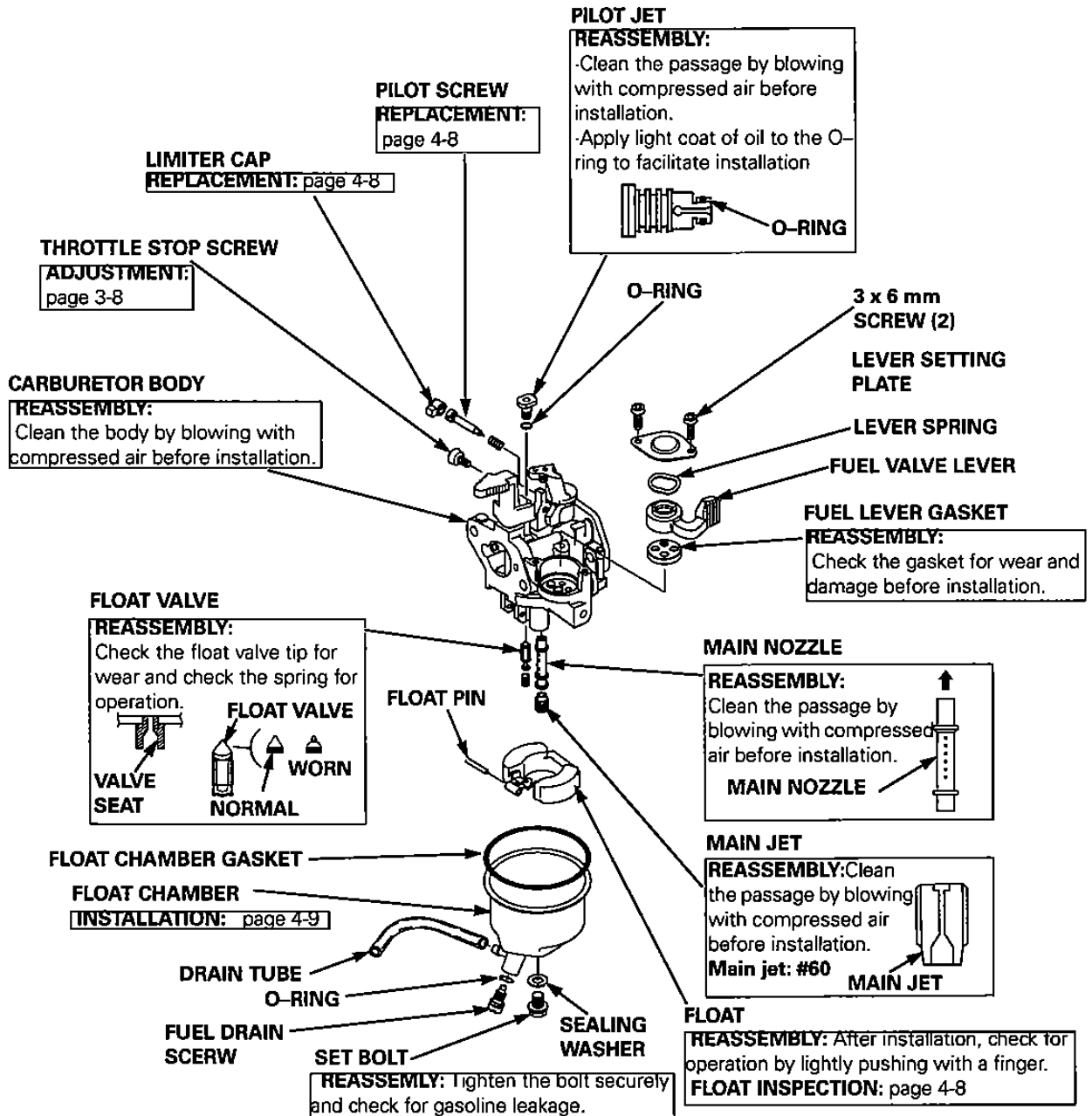

FUEL SYSTEM

REPLACEMENT

Pilot screw and limiter cap

Leave the pilot screw and limiter cap in place during carburetor cleaning. Remove only if necessary for carburetor repair.

Removal of the limiter cap requires breaking the pilot screw.

A new pilot screw and limiter cap must be installed.

1. When the limiter cap has been broken off, remove the broken pilot screw from the carburetor body.
2. Place the spring on the replacement pilot screw, and install it on the carburetor.
3. Turn the pilot screw in until it is lightly seated, then turn the screw out the required number of turns.

Standard pilot screw opening

2 - 3/8 turns out

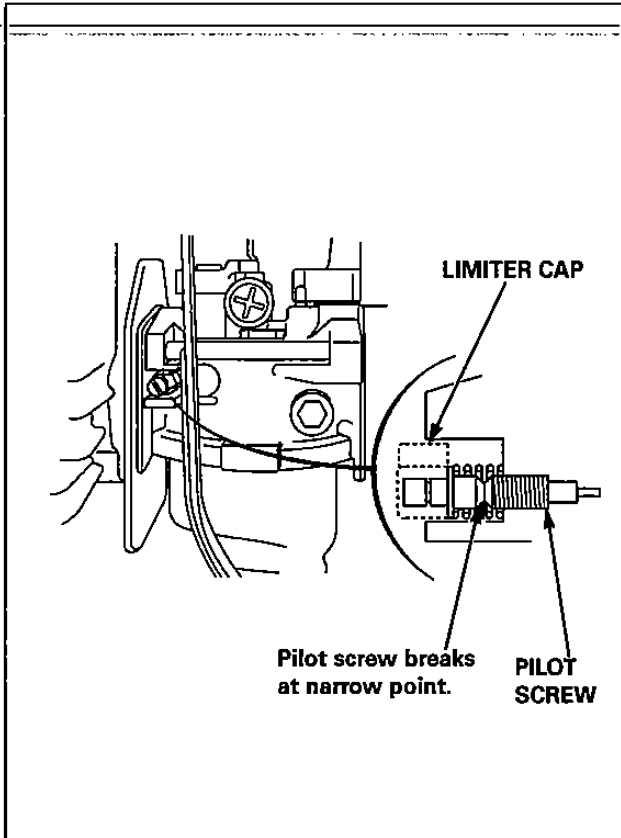

4. Apply LOCTITE® 638 to the inside of the new limiter cap, then install the cap so its stop prevents the pilot screw from being turned counterclockwise.

Be careful to avoid turning the pilot screw while installing the limiter cap. The pilot screw must stay at its required setting position.

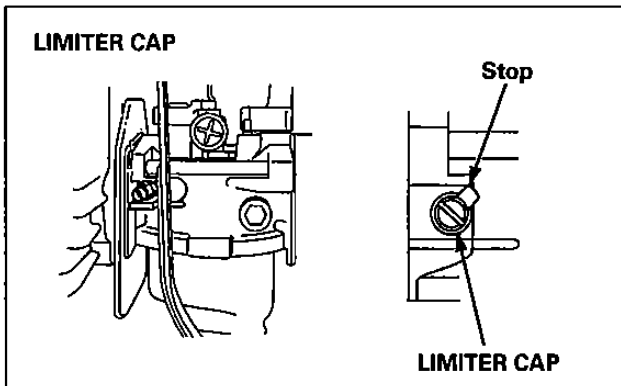

INSPECTION

Float level height

Place the carburetor in the position as shown and measure the distance between the float top and carburetor body when the float just contacts the seat without compressing the valve spring.

Standard float height 12 mm (0.5 in)

If the height is out of specification, replace the float and/or the float valve. Recheck the float height.

TOOL:

Float level gauge

07401-0010000

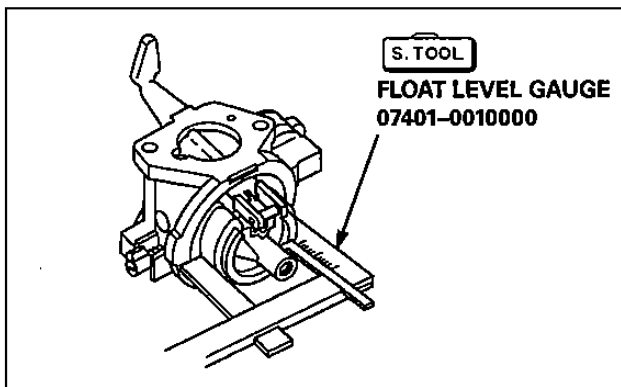

INSTALLATION

Governor rod/Throttle return spring

1. First, install the governor rod on the carburetor throttle lever.
2. Hook the throttle return spring on the carburetor throttle lever.

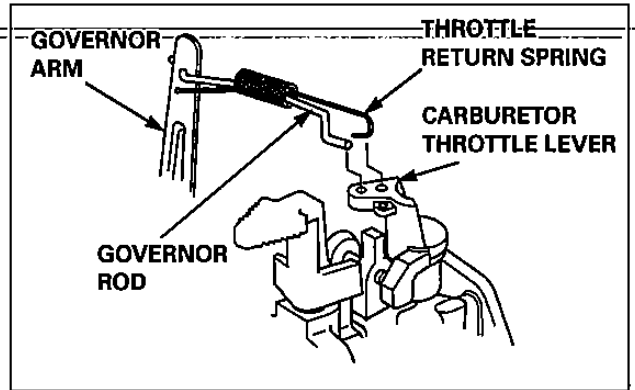

FLOAT CHAMBER

Install with the drain screw facing to the air cleaner side.

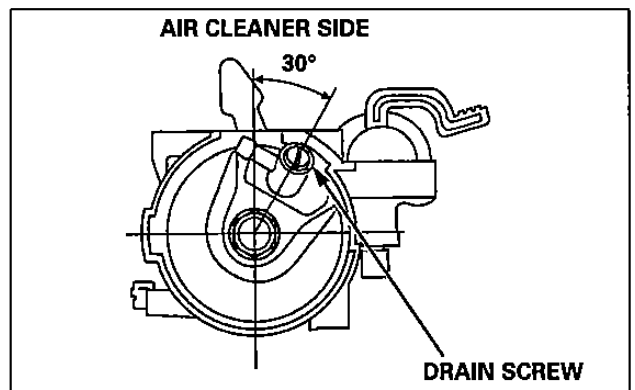

MEMO

5. CONTROL BASE/GOVERNOR ARM



CONTROL BASE/GOVERNOR ARM 5-2

CONTROL BASE/GOVERNOR ARM

CONTROL BASE/GOVERNOR ARM

REMOVAL/INSTALLATION

1. Remove the air cleaner (page 4-4)
2. Remove the carburetor (page 4-6)

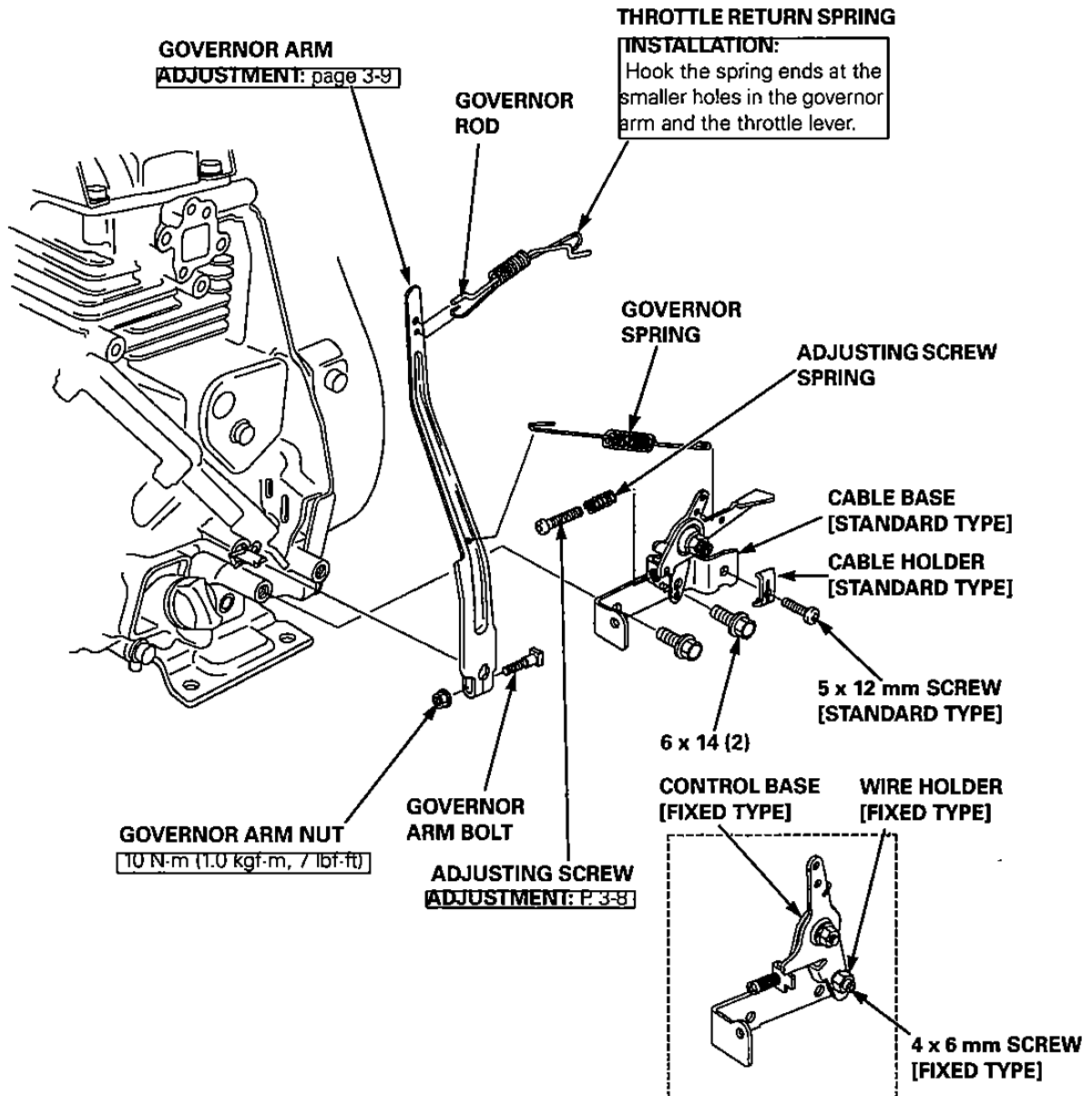

6. MUFFLER



MUFFLER 6-2

MUFFLER

MUFFLER

REMOVAL/INSTALLATION

⚠ CAUTION

The engine and muffler become very hot during operation and they remain hot for a while after operation. The muffler removal/installation must be made while the engine is cold.

 :Type with muffler deflector only.

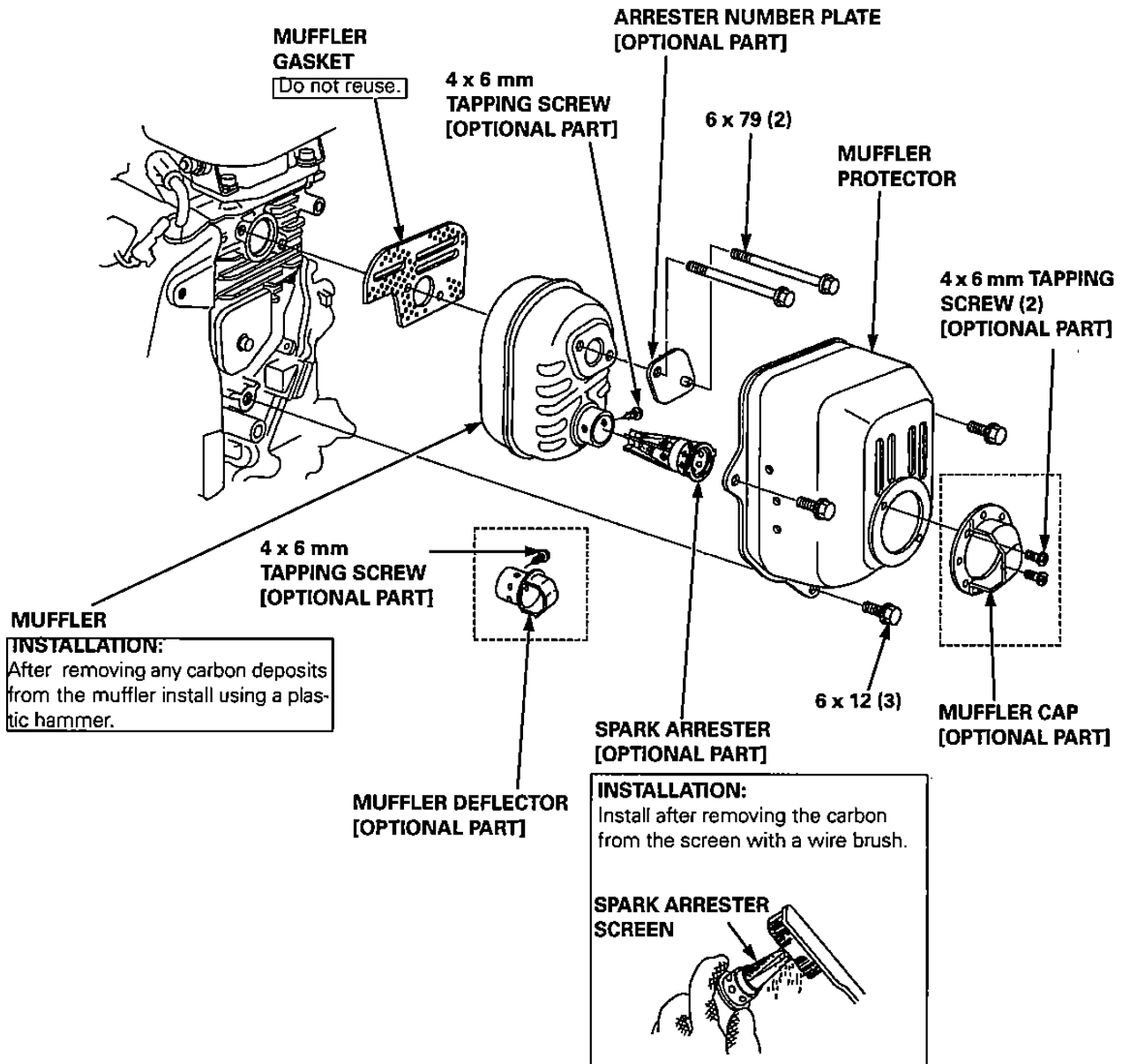

7. RECOIL STARTER/FAN COVER/ENGINE STOP SWITCH

**RECOIL STARTER
/FAN COVER/ENGINE STOP SWITCH..... 7-2**

OIL ALERT ESS (TYPE WITH OIL ALERT).....7-6

RECOIL STARTER/FAN COVER/ENGINE STOP SWITCH

RECOIL STARTER/FAN COVER/ ENGINE STOP SWITCH

REMOVAL/INSTALLATION

 :Type with oil alert only.

- If the starter rope has been frayed or worn out, replace the starter rope.
 - Do not disassemble the recoil starter assembly.
1. Remove the cable clip A and stop switch wire (Type with oil alert).
 2. Disconnect the engine stop switch wire connector.
 3. Remove the muffler protector (page 6-2).

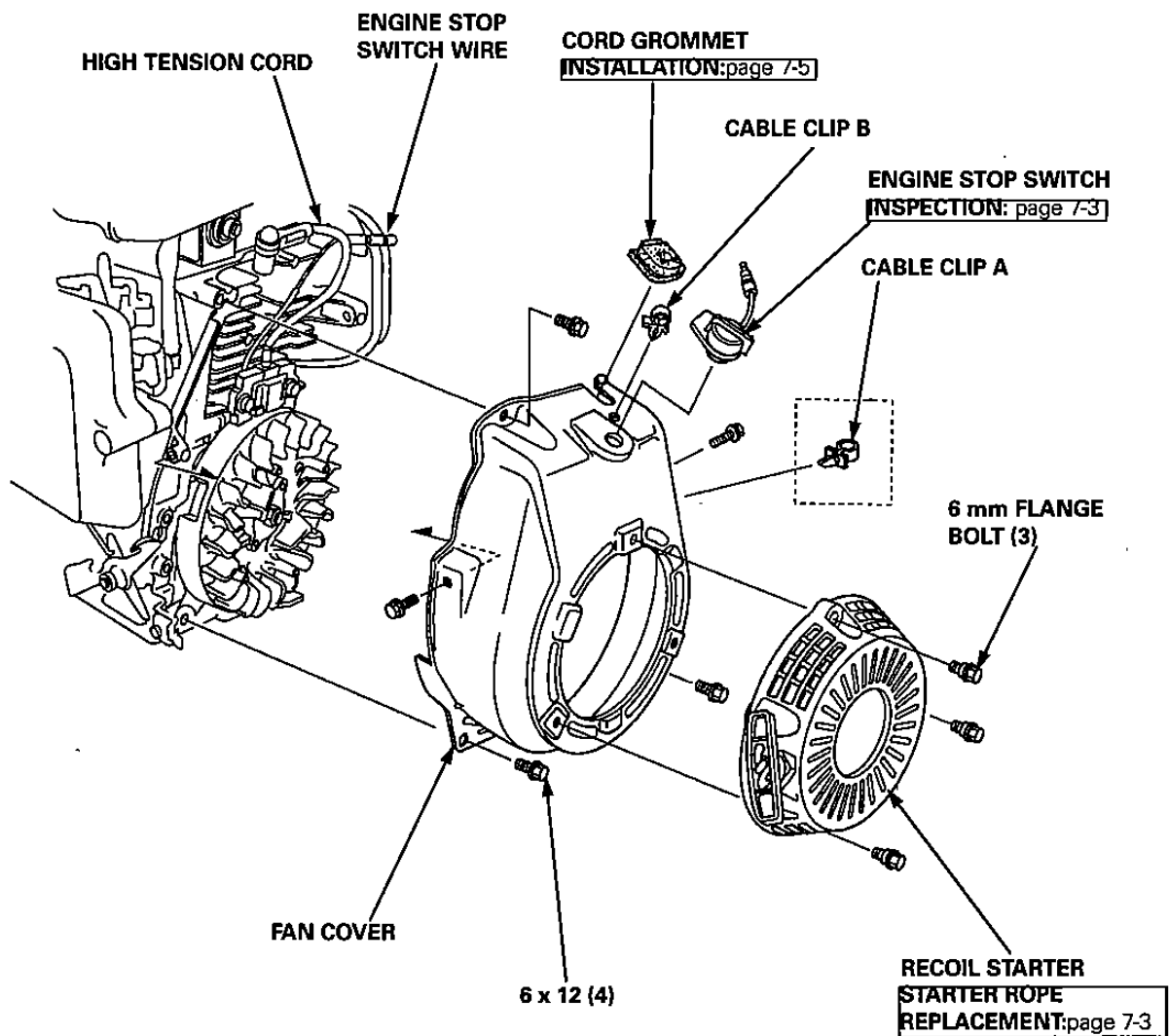

RECOIL STARTER/FAN COVER/ENGINE STOP SWITCH

INSPECTION

Engine stop switch

Attach the tester leads to the black wire and the ground plate of the engine stop switch, and check for continuity.

Switch OFF position: There should be continuity.

Switch ON position: There should be no continuity.

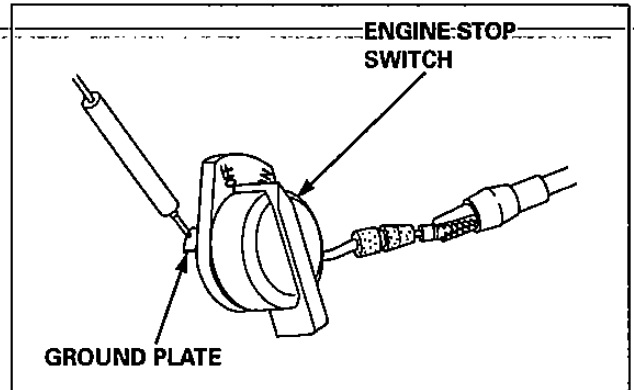

STARTER ROPE REPLACEMENT

1. Pull the starter grip fully (until the starter rope is pulled out fully).

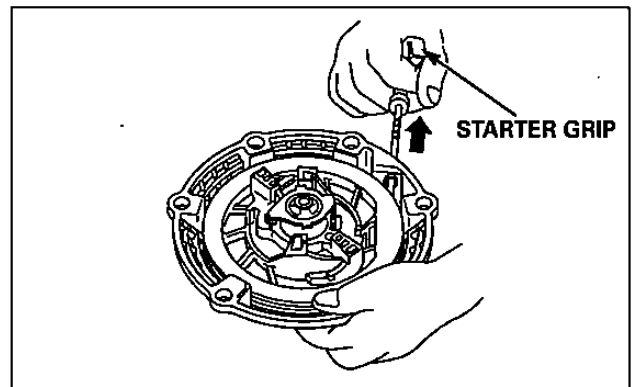

2. To prevent the starter reel from rewinding, hold the starter reel and starter case with a band or equivalent material as shown.

3. Untie the knots of the starter rope at the starter grip side and the starter reel side, and remove the starter rope.

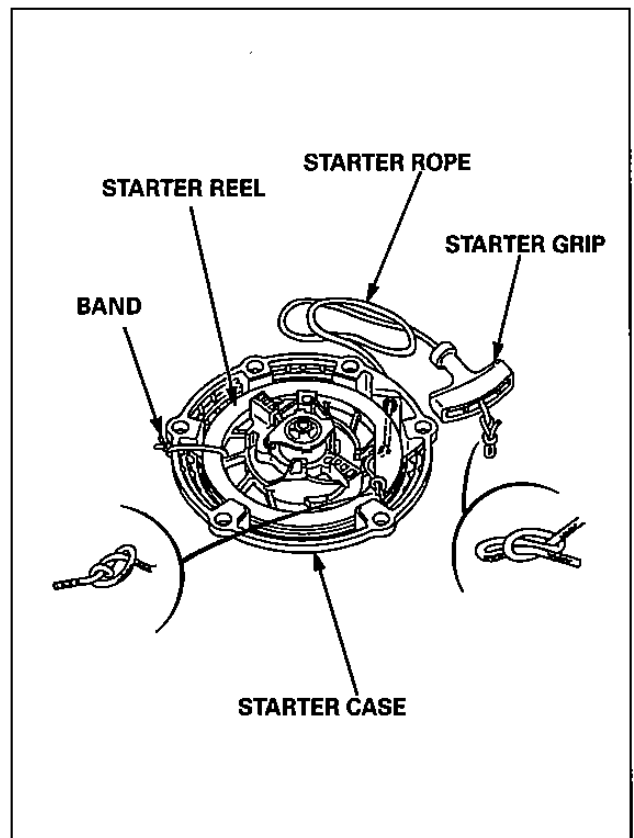

RECOIL STARTER/FAN COVER/ENGINE STOP SWITCH

4. When the starter rope has broken or the starter reel has rewound, align the rope hole in the starter case with the rope hole in the starter reel by turning the starter reel 5 turns in the direction of the arrow.

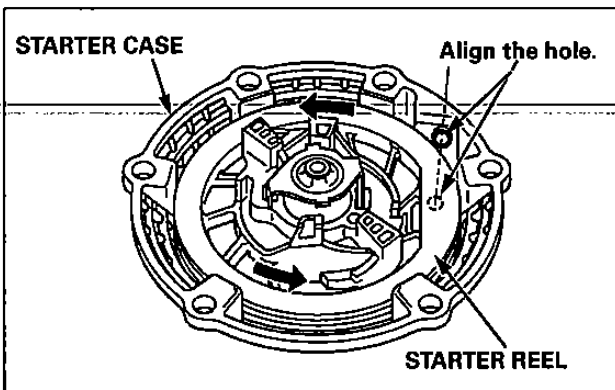

5. Make a knot at the ends of the starter rope, i.e. at the reel side end and the starter grip side end, as shown at 20 mm (0.8 in) from the ends of the rope.

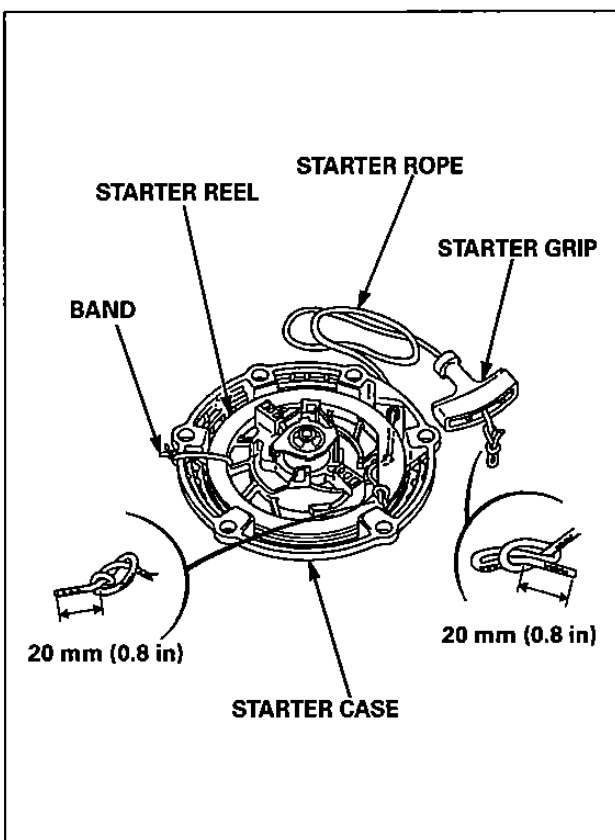

6. Wind the starter rope slowly on the starter reel.
7. Check the operation of the ratchet by pulling the starter rope several times.

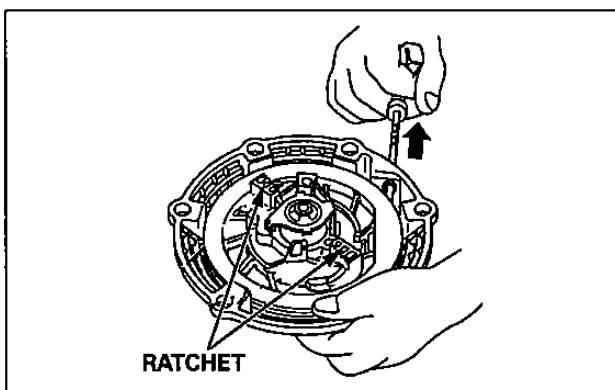

RECOIL STARTER/FAN COVER/ENGINE STOP SWITCH

CORD GROMMET INSTALLATION

Set wire and high tension cord in the grooves in the cord grommet as shown.

Type without oil alert:

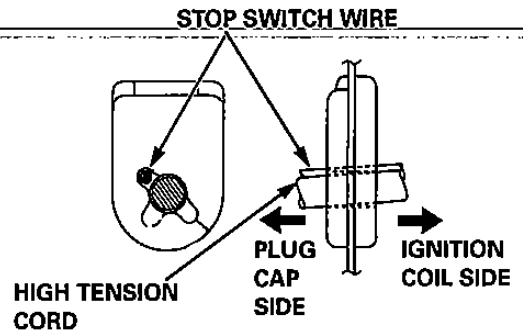

Type with oil alert:

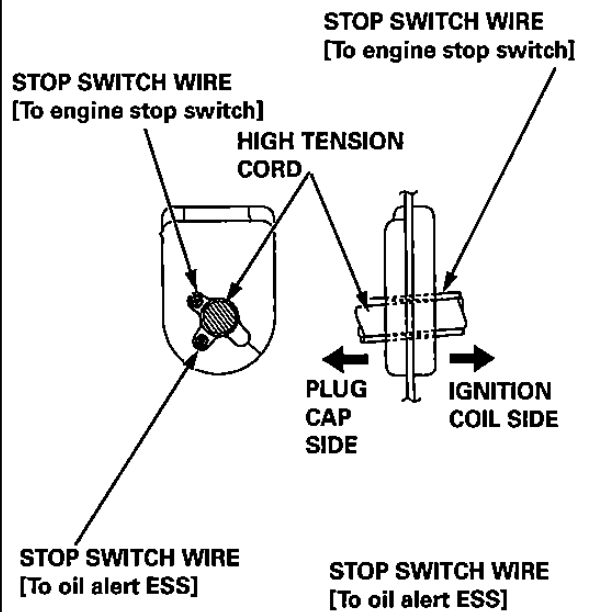

RECOIL STARTER/FAN COVER/ENGINE STOP SWITCH
OIL ALERT ESS (TYPE WITH OIL ALERT)
REMOVAL/INSTALLATION

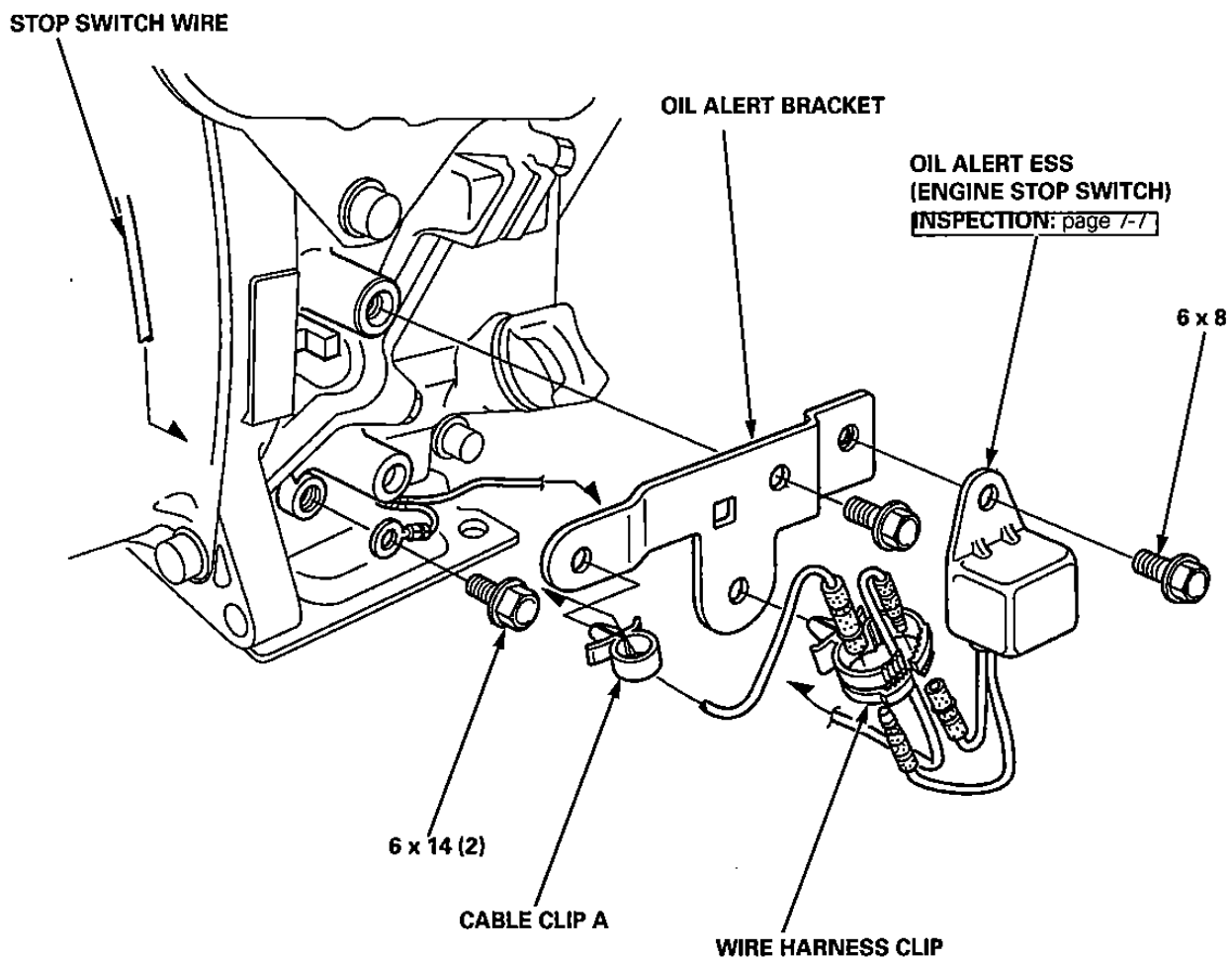

RECOIL STARTER/FAN COVER/ENGINE STOP SWITCH

INSPECTION

Oil alert ESS (Engine Stop Switch)

Measure the resistance between the black and yellow wires, and between each of the black and yellow wires and the oil alert ESS body.

If the measurement is out of the specifications shown in the chart below, replace the oil alert ESS.

(+)tester probe (-)tester probe	Black	Yellow	Body
Black	-	500 - 10 k Ω	∞
Yellow	500 - 10 k Ω	-	∞
Body	∞	∞	-

- Take care not to touch the tester probe during inspection. Human body resistance is indicated when you touch the metallic part of the tester probe.
- Be sure to use the recommended tester listed below. Incorrect resistance will be shown by the use of an unrecommended tester.
- When an abnormal resistance is shown, check the tester battery. Correct resistance cannot be obtained by the use of undercharged battery.

Recommended tester: 20 k Ω /VDC, 9 k Ω /VAC (Impedance)

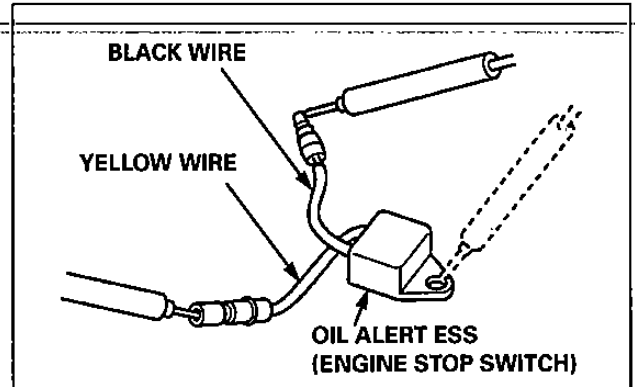

RECOIL STARTER/FAN COVER/ENGINE STOP SWITCH

8. FLYWHEEL/IGNITION COIL

FLYWHEEL/IGNITION COIL 8-2

BREATHER COVER A/B 8-6



FLYWHEEL/IGNITION COIL

FLYWHEEL/IGNITION COIL

DISASSEMBLY/REASSEMBLY

 Type with oil alert only.

NOTICE

Take care not to damage the fan blades during removal and installation of the flywheel.

1. Remove the fuel tank (page 4-2).
2. Remove the air cleaner (page 4-4) and carburetor (page 4-6).
3. Remove the control base and governor arm (page 5-2)
4. Remove the recoil starter and fan cover (page 7-2)

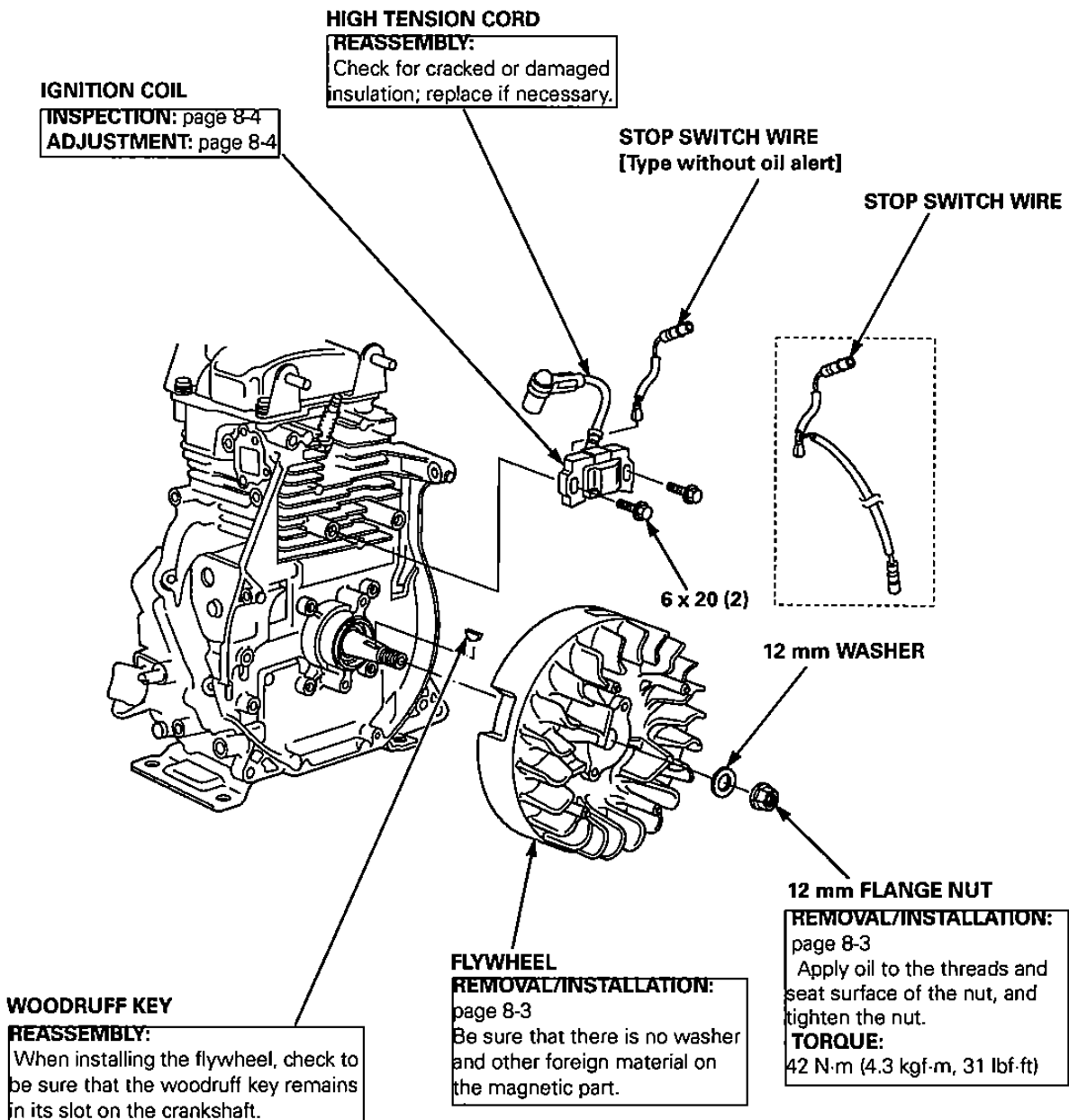

12 mm Flange nut/Flywheel removal:

1. Remove the ignition coil (page 8-2).
2. Holding the flywheel with a commercially available strap wrench, remove the 12 mm flange nut and washer.

STRAP WRENCH

(Commercially available)

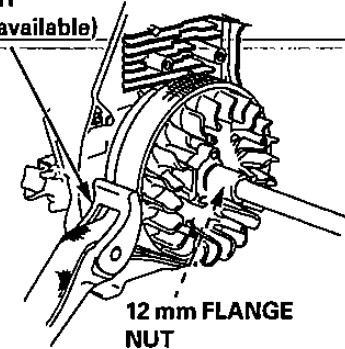

12 mm FLANGE NUT

3. Use a commercially available 6-inch flywheel puller on the flywheel; place the jaws of the puller so they are at the cutouts of the flywheel.
4. Tighten the flywheel puller and remove the flywheel.

NOTICE

Do not hit the flywheel with a hammer.

CUTOUTS

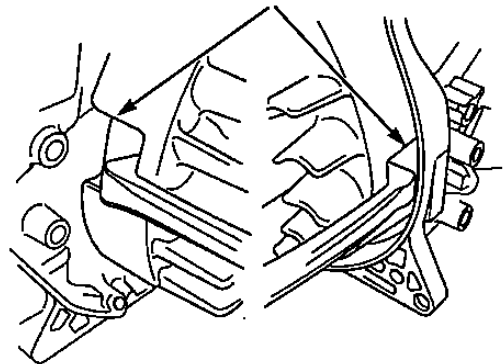

FLYWHEEL PULLER

(Commercially available)

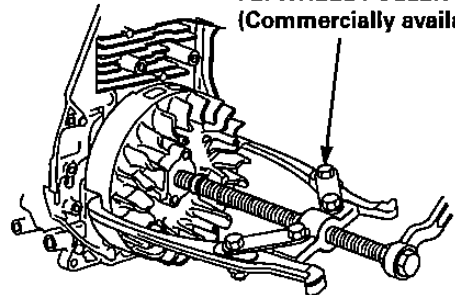

12 mm Flange nut/Flywheel installation:

1. Clean the tapered part of dirt, oil, grease and other foreign material before installation. Be sure that there is no washer and other foreign material on the magnetic part.
2. Set the woodruff key in the key groove securely (page 8-2)
3. Install the flywheel over the crankshaft.
4. Apply light coat of the oil to the threads and the seating surface of the 12 mm flange nut, and install the nut loosely.
5. Holding the flywheel with a commercially available strap wrench, tighten the 12 mm flange nut to the specified torque.

TORQUE: 42 N·m (4.3 kgf·m, 31 lbf·ft)

6. Install the ignition coil and adjust the air gap (page 8-4)

STRAP WRENCH

(Commercially available)

12 mm FLANGE NUT

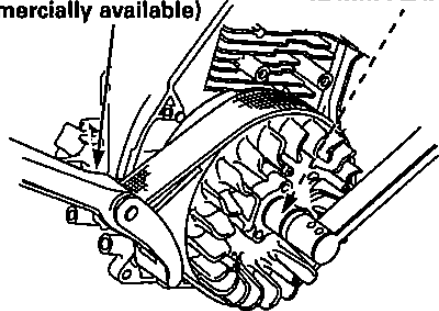

FLYWHEEL/IGNITION COIL

INSPECTION

Ignition coil Primary coil:

Measure the resistance of the primary coil by attaching one ohmmeter lead to the ignition coil's primary terminal while touching the other test lead to the iron core.

Resistance 0.75 – 0.95Ω

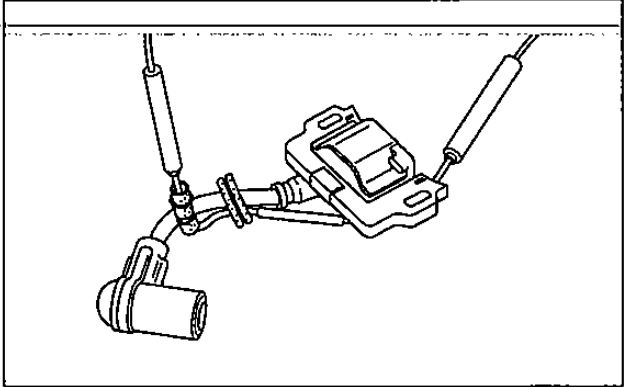

Ignition coil Secondary coil:

Attach a tester lead between the spark plug cap and iron core, and measure the resistance of the secondary coil.

Resistance 6.1 – 9.3 kΩ

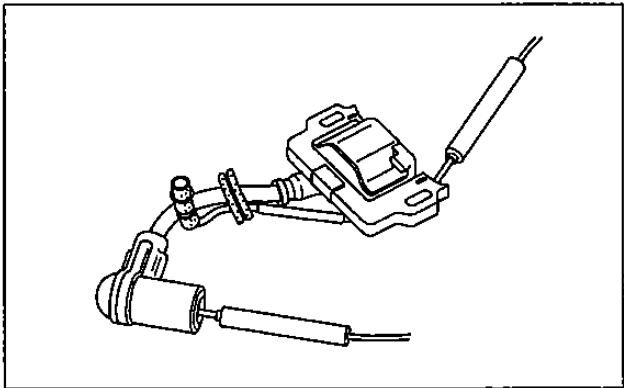

ADJUSTMENT

Ignition coil air gap

Adjustment is required only when the ignition coil or the flywheel has been removed.

1. Loosen the two ignition coil bolts.
2. Insert a long feeler gauge of the proper thickness between the ignition coil and the flywheel.

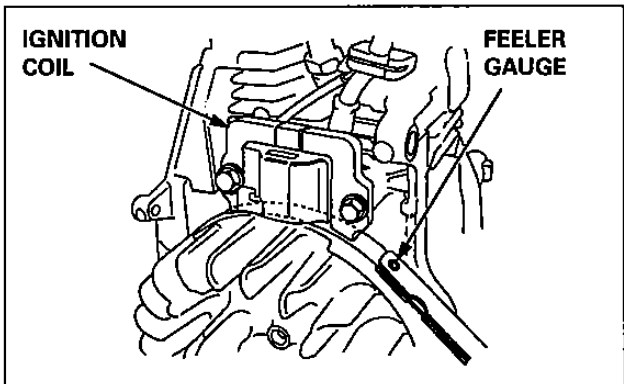

FLYWHEEL/IGNITION COIL

3. Push the ignition coil firmly toward the flywheel and tighten the bolts.

Specified clearance 0.2 – 0.5 mm (0.008 – 0.020 in)

- Avoid the flywheel magnet when adjusting the ignition coil air gap.

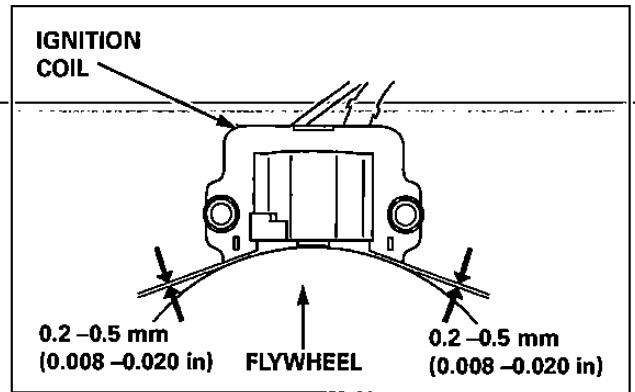

FLYWHEEL/IGNITION COIL

BREATHER COVER A/B

DISASSEMBLY/REASSEMBLY

Breather cover A:

Remove the muffler (page 6-2).

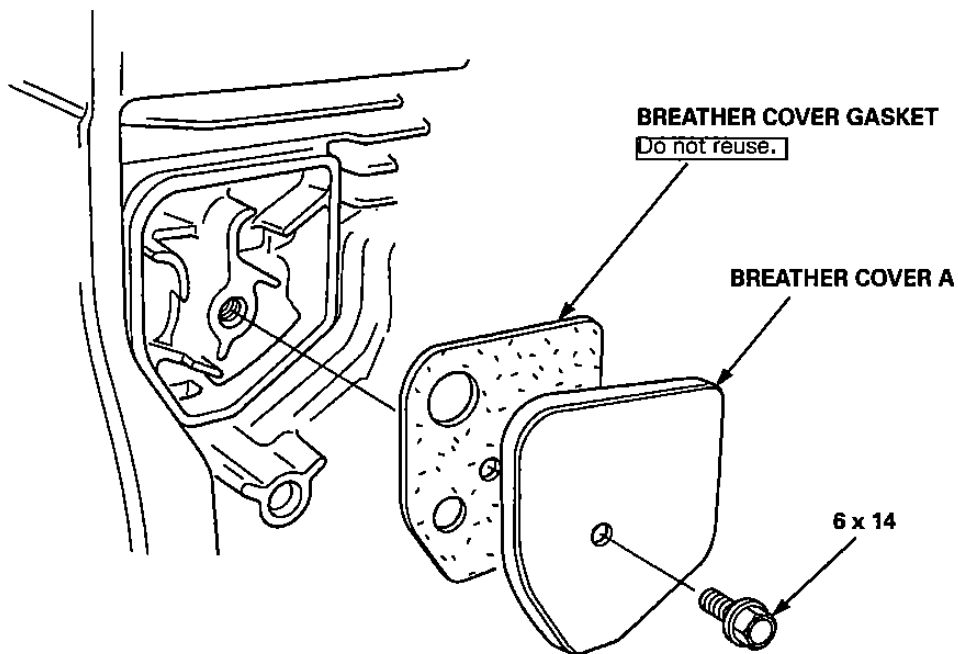

Breather cover B:

Remove the air cleaner and carburetor (page 4-4)(page 4-6).

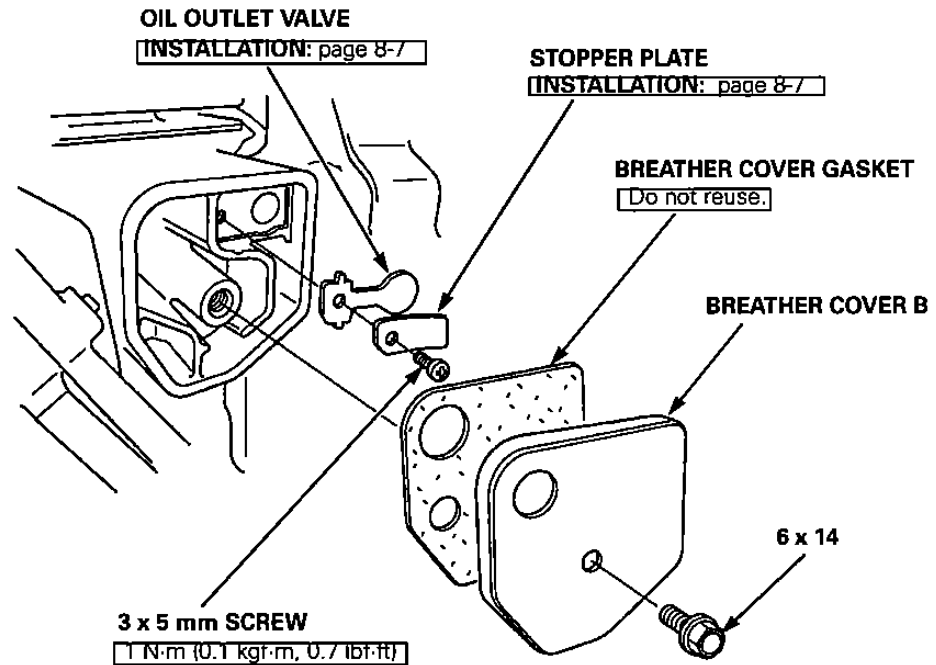

Outlet valve/Stopper plate installation:

1. Clean the oil outlet valve, stopper plate and the valve installation area of the cylinder barrel.
2. Install the valve aligning the positioning projections and chamfer of the valve with the groove and chamfer of the cylinder barrel.
3. Install the stopper plate on the valve aligning the chamfer of the stopper plate with the chamfer of the cylinder barrel.
4. Tighten the 3 x 5 mm screw securely.

TORQUE: 1 N·m (0.1 kgf·m, 0.7 lbf·ft)

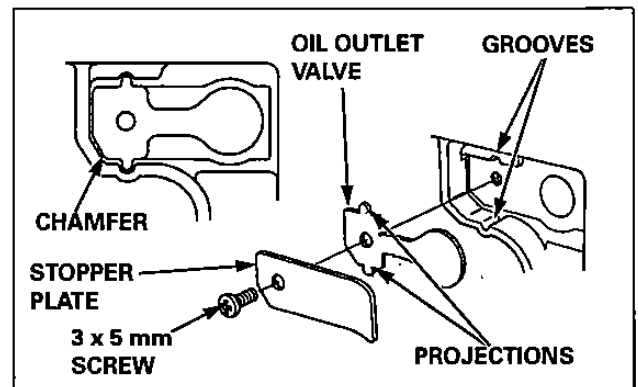

FLYWHEEL/IGNITION COIL

9. CAM PULLEY/CRANKSHAFT/PISTON/CYLINDER BARREL

CAM PULLEY	9-2	GOVERNOR	9-15
CRANKCASE COVER/CRANKSHAFT /CYLINDER BARREL.....	9-6	INSPECTION	9-18
PISTON.....	9-11	VALVE GUIDE REPLACEMENT	9-27
VALVES.....	9-13	VALVE SEAT RECONDITIONING	9-29

CAM PULLEY/CRANKSHAFT/PISTON/CYLINDER BARREL

CAM PULLEY

REMOVAL/INSTALLATION

1. Remove the fuel tank (page 4-2) and fuel tank stay A/B (page 4-3).
2. Remove the air cleaner (page 4-4) and carburetor (page 4-6).
3. Remove the control base and governor arm (page 5-2).
4. Remove the recoil starter and fan cover (page 7-2).
5. Remove the muffler (page 6-2).

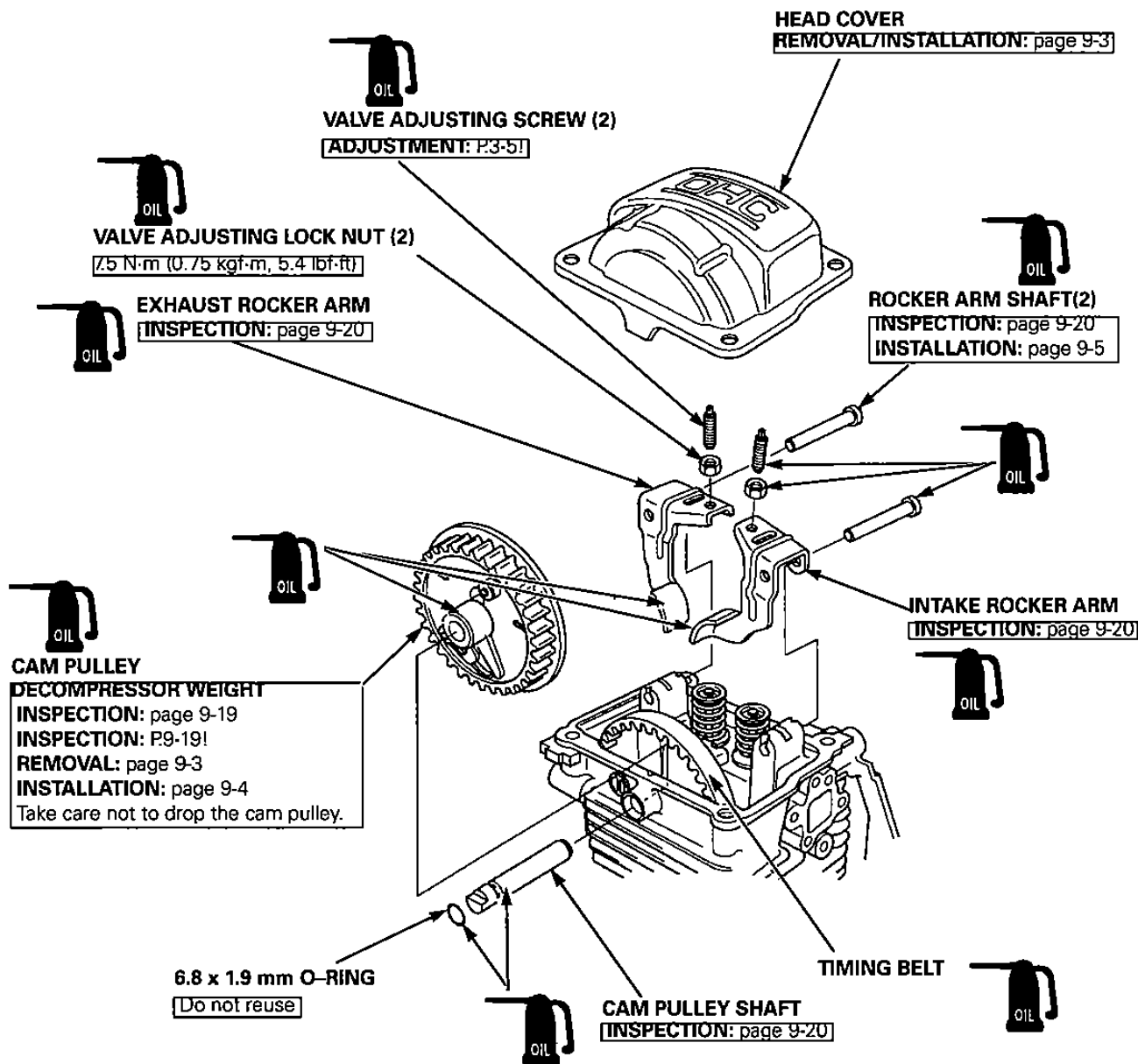

CAM PULLEY/CRANKSHAFT/PISTON/CYLINDER BARREL

Head cover removal:

1. Remove the four 6 x 12 mm flange bolts.
 2. To remove the head cover, insert a screw driver or equivalent tool into the recess in the position of the cylinder shown. Remove the head cover slowly.
- Clean up any spilled engine oil with a shop towel when removing the head cover.

NOTICE

- Do not remove the head cover with force, because that can deform the head cover.
- Replace the head cover if it is deformed.

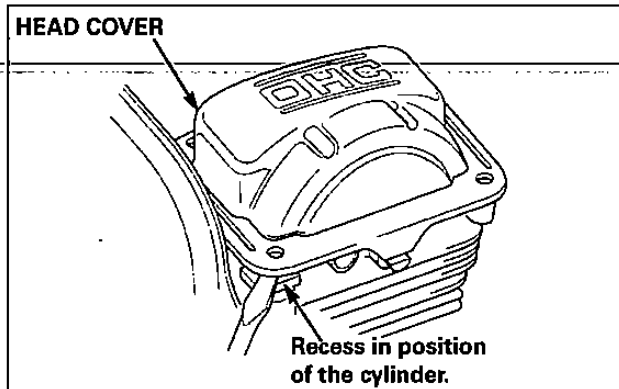

Head cover installation:

1. Clean the mating surfaces of the head cover and the cylinder using a degreasing cleaning agent or a clean shop towel.
2. Apply a bead [$\phi 1.5 - 2.0$ mm ($\phi 0.06 - 0.08$ in)] of liquid gasket (Three Bond #1207B, Honda Bond #4 or equivalent) to the head cover; specifically to the inner wall of the groove and bolt holes in the head cover.
Assemble within 10 minutes after applying the liquid gasket.
3. Wait for approximately 20 minutes after assembly before filling with oil and starting the engine.

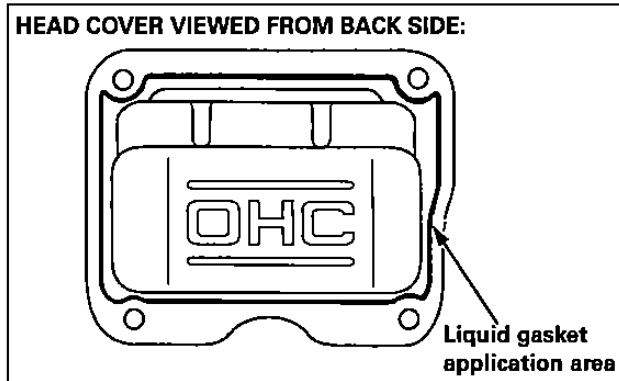

Cam pulley removal:

1. Remove the spark plug and head cover.
2. Set the piston top dead center of the compression stroke (both valves fully closed). Align the cutout in the flywheel fin or the alignment mark on the flywheel with the top hole on the fan cover.
The top dead center of the compression stroke is in the position where the head cover mating surface is in line with the cam pulley alignment marks.
3. Remove the intake and exhaust rocker arms and the rocker arm shafts (page 9-2).
Remove the cam pulley shaft from the cam pulley (page 9-2).

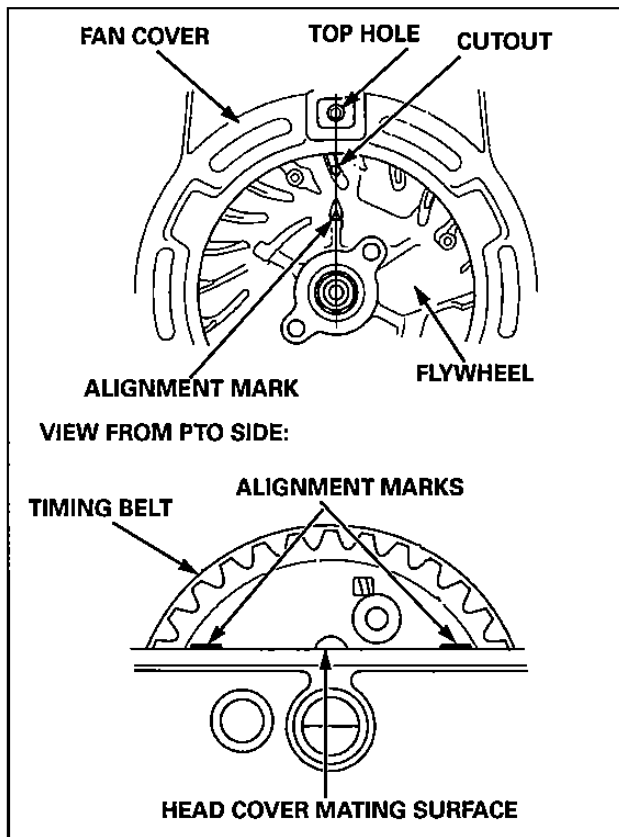

CAM PULLEY/CRANKSHAFT/PISTON/CYLINDER BARREL

4. Push the cam pulley into the cylinder a little. Detach the timing belt from the flange side of the cam pulley as shown, and remove the cam pulley.

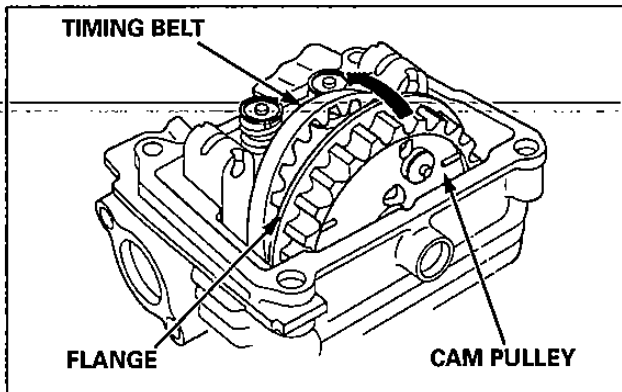

Cam pulley installation:

1. Set the piston top dead center of the compression stroke (both valves fully closed). Align the cutout in the flywheel fin or the alignment mark on the flywheel with the top hole on the fan cover.

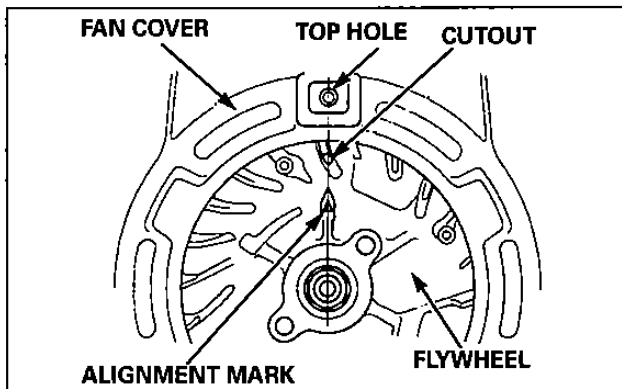

2. Set the timing belt on the cam pulley from the flange side of the cam pulley.
3. Align the alignment marks on the cam pulley so that they are in line with the head cover mating surface.

The top dead center of the compression stroke is in the position where the head cover mating surface is in line with the cam pulley alignment marks.

Be careful to avoid turning the crankshaft when installing.

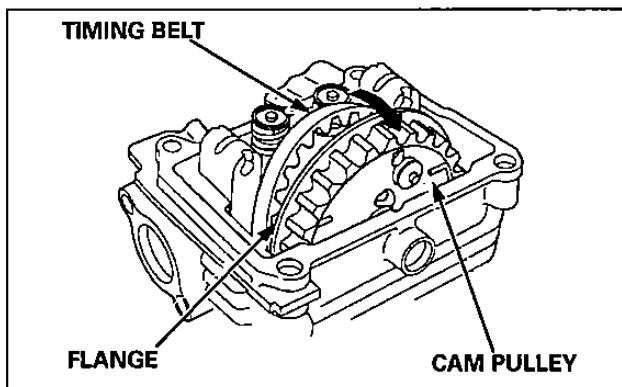

4. Apply oil to the 6.8 x 1.9 mm O-ring and install it on the cam pulley shaft (page 9-2)
5. Install the cam pulley shaft in the cylinder (page 9-2).
6. Holding the cam pulley alignment marks in line with the head cover mating surface, check again whether the piston is at the top dead center of the compression stroke.
7. If the alignment marks and the head cover mating surface are out of alignment or if the piston is not at the top dead center of the compression stroke, repeat the procedure from the step 1.

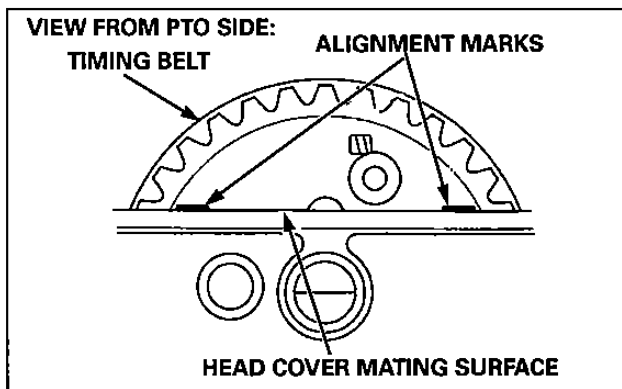

CAM PULLEY/CRANKSHAFT/PISTON/CYLINDER BARREL

Rocker arm shaft installation:

Install the rocker arm shaft from the opposite side of the cam pulley as shown.

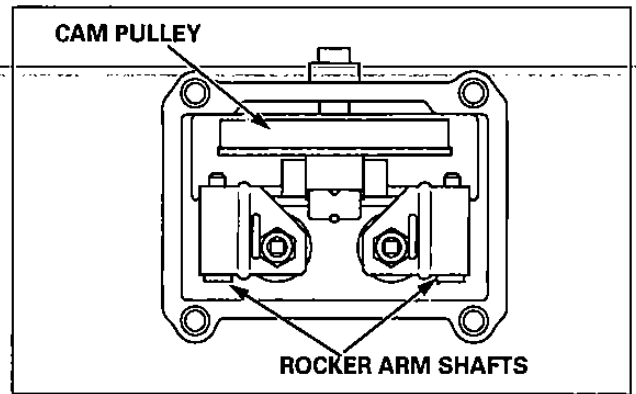

CAM PULLEY/CRANKSHAFT/PISTON/CYLINDER BARREL

CRANKCASE COVER/CRANKSHAFT/ CYLINDER BARREL

REMOVAL/INSTALLATION

Remove the cam pulley and rocker arm (page 9-2)

CRANKCASE COVER ASSEMBLY

DISASSEMBLY/REASSEMBLY: page 9-15
REMOVAL: page 9-7

6 x 25 (8)

INSTALLATION: page 9-9

GREASE (Apply grease to the lips.)

ENGINE BED

8 x 25 (4)

TIMING BELT

Specified belt: 6T YU7 G-200

INSTALLATION: P.9-8!

Check that the belt is not worn or cracked and do not bend or twist the belt.

PISTON ASSEMBLY

DISASSEMBLY/
REASSEMBLY: page 9-11
INSPECTION: P.9-20 and 21!
INSTALLATION: page 9-8

CRANKSHAFT

INSPECTION: P.9-22 and 23!

INSTALLATION: page 9-9

Be careful not to damage the oil seal.
After installation, clean the crankshaft tapered surface.

8 x 20 mm DOWEL PIN (2)

CONNECTING ROD CAP

INSTALLATION: page 9-8

CONNECTING
ROD BOLT (2)

5 N·m (0.5 kgf·m, 3.6 lbf·ft)

6204 RADIAL BALL BEARING

INSPECTION: page 9-19

REMOVAL/INSTALLATION: page 9-7

CYLINDER BARREL

INSPECTION: P.9-20!

INSTALLATION: page 9-9

20 x 32 x 6 mm OIL SEAL

INSTALLATION: page 9-17

Be careful not to damage the lip of the oil seal when installing the crankcase cover with the oil seal.

GREASE (Apply grease to the lips.)

CAM PULLY/CRANKSHAFT/PISTON/CYLINDER BARREL

Crankcase cover assembly removal:

1. Remove the eight 6 x 25 mm flange bolts.
2. Insert a screw driver or equivalent tool into the recess as shown, and remove the crankshaft cover from the cylinder barrel.

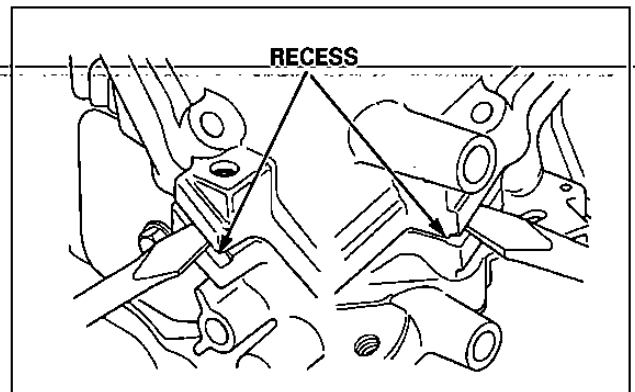

6204 Radial ball bearing removal:

Pull the bearing off the crankshaft, using a commercially available bearing puller.

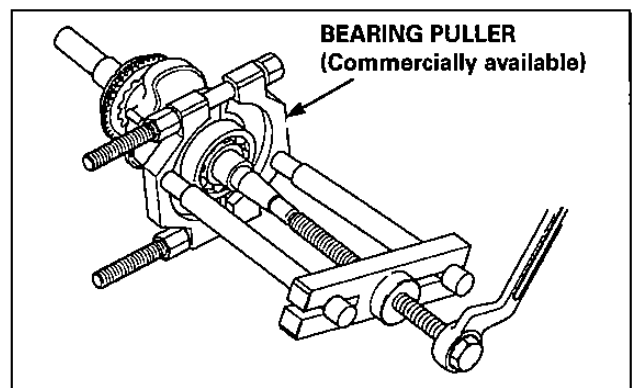

6204 Radial ball bearing installation:

1. Apply oil to the circumference of a new radial ball bearing.
2. Drive the radial ball bearing onto the crankshaft, using the special tools.

TOOLS:

Driver, 22 mm I.D.

07746-0020100

Attachment, 20 mm I.D.

07746-0020400

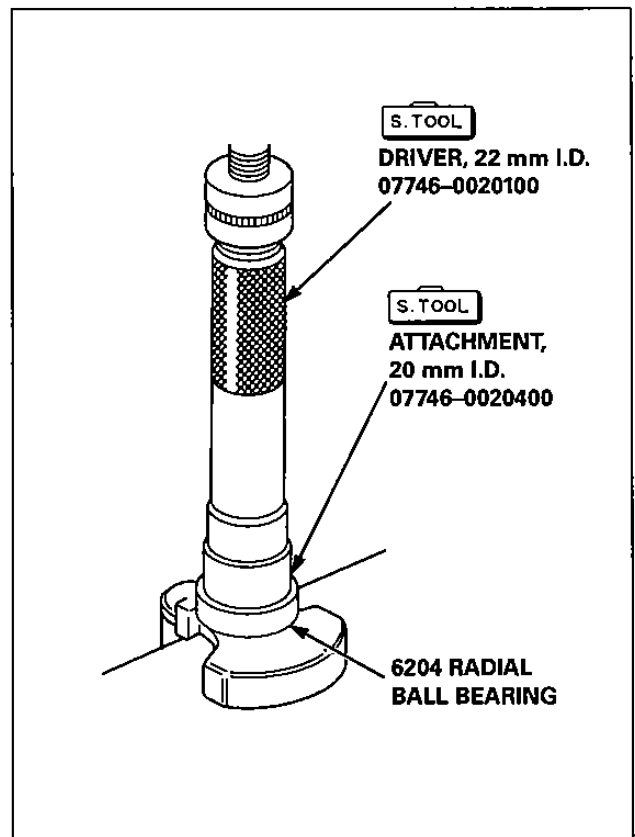

CAM PULLY/CRANKSHAFT/PISTON/CYLINDER BARREL

Piston assembly/Connecting rod cap installation:

- When the piston and connecting rod are disassembled, check that the piston is properly assembled with the connecting rod.

Assemble the piston and connecting rod properly if necessary (page 9-12).

- Perform the following after checking that the piston and connecting rod are installed properly.

1. Apply oil to the inner wall of the cylinder, outer surface of the piston and to the inner wall of the connecting rod big end.
2. Install the piston assembly in the cylinder barrel with the cam pulley mounting part facing up. Be sure that the "▼" mark of the "FW ▼" mark on the piston skirt inside points down (toward the flywheel) when the longer side of the connecting rod long end is facing to the right as shown.

The piston must be at the top dead center of the compression stroke.

- Take care not to break the piston ring when installing the piston assembly in the cylinder.

3. Apply oil to the crank pin and journal.
4. Install the crankcase in the cylinder barrel (page 9-6)

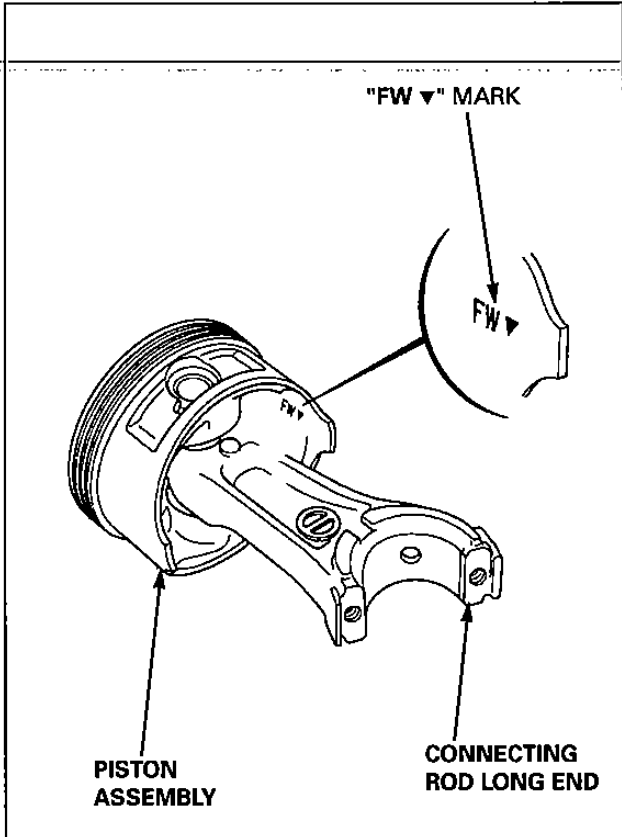

5. Apply oil to the connecting rod cap bearing.
6. Install by aligning the alignment marks on the connecting rod big end and connecting rod cap.
7. Apply oil to the threaded part and seat of the connecting rod bolts. Tighten the connecting rod bolts to the specified torque.

TORQUE: 5 N·m (0.5 kgf·m, 3.6 lbf·ft)

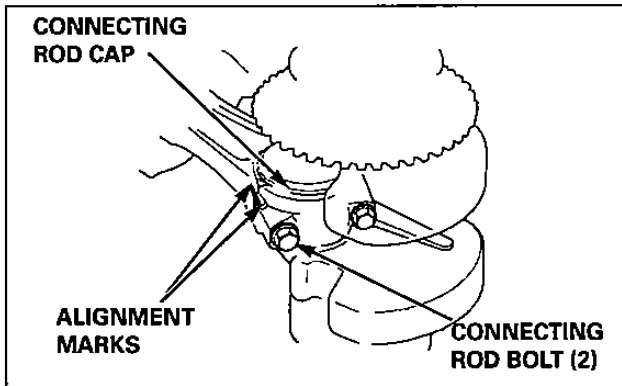

CAM PULLY/CRANKSHAFT/PISTON/CYLINDER BARREL

20 x 32 x 6 mm Oil seal installation:

<Cylinder barrel side>

1. Apply oil to the outside of the new oil seal.
2. Install the new oil seal on the cylinder barrel using the special tools as shown.

TOOLS:

Driver	07749-0010000
Attachment, 32 x 35 mm	07746-0010100
Pilot, 20 mm	07746-0040500

3. After installation, apply grease to the lip.

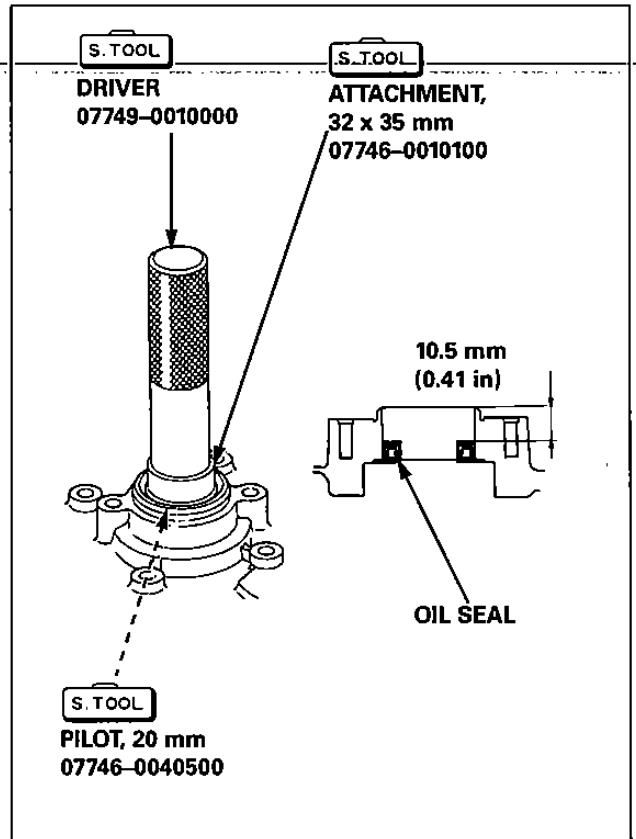

Crankshaft/Cylinder barrel/Timing belt/6 x 25 mm Flange bolt installation:

1. Install the piston/connecting rod assembly in the cylinder barrel (page 9-8)
2. Align the "■" mark on the cylinder barrel with the "■" mark on the crankshaft.

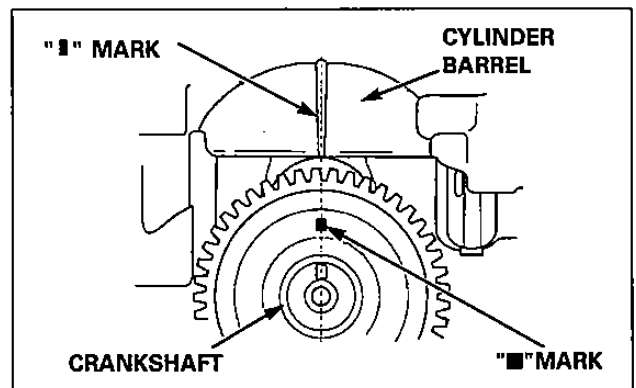

3. Set the timing belt on the timing belt drive pulley so that the marks on the timing belt are upside down as shown.
4. After installing the timing belt, install the respective cam pulley (page 9-4).

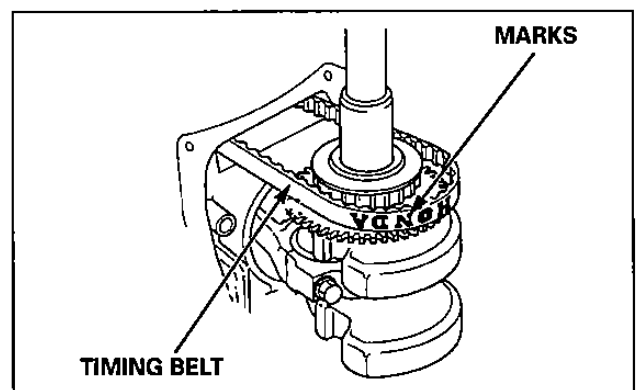

CAM PULLY/CRANKSHAFT/PISTON/CYLINDER BARREL

5. Clean the mating surfaces of the cylinder barrel and the crankcase cover using a degreasing cleaning agent or a clean shop towel.

6. Set the 8 x 20 mm dowel pins on the cylinder barrel.

7. Apply a bead [$\phi 1.5 - 2.0$ mm ($\phi 0.06 - 0.08$ in)] of liquid gasket (Three bond #1207B, Honda Bond #4 or equivalent) to the cylinder barrel; specifically, to the mating surface with the crankcase cover.

8. Install the crankcase cover on the cylinder barrel.

- Assemble within 10 minutes after applying the liquid gasket.
- If it is hard to install the crankcase cover securely, assemble by turning the crankshaft a little.

9. Loosely tighten each 6 x 25 mm flange bolt, then tighten to the numbered sequence.

10. Wait for approximately 20 minutes after assembly before filling oil and starting the engine.

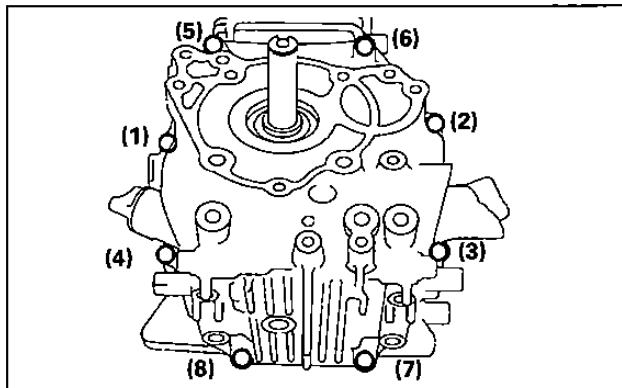
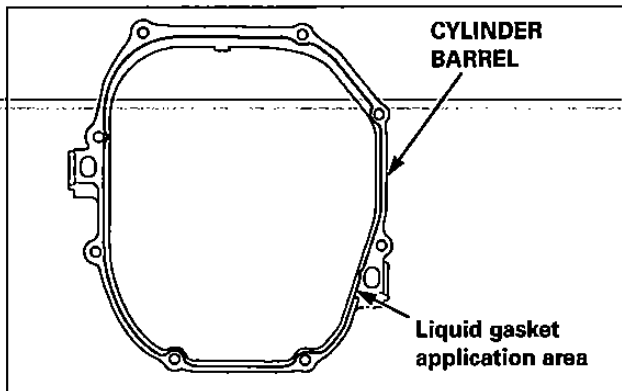

PISTON

DISASSEMBLY/REASSEMBLY

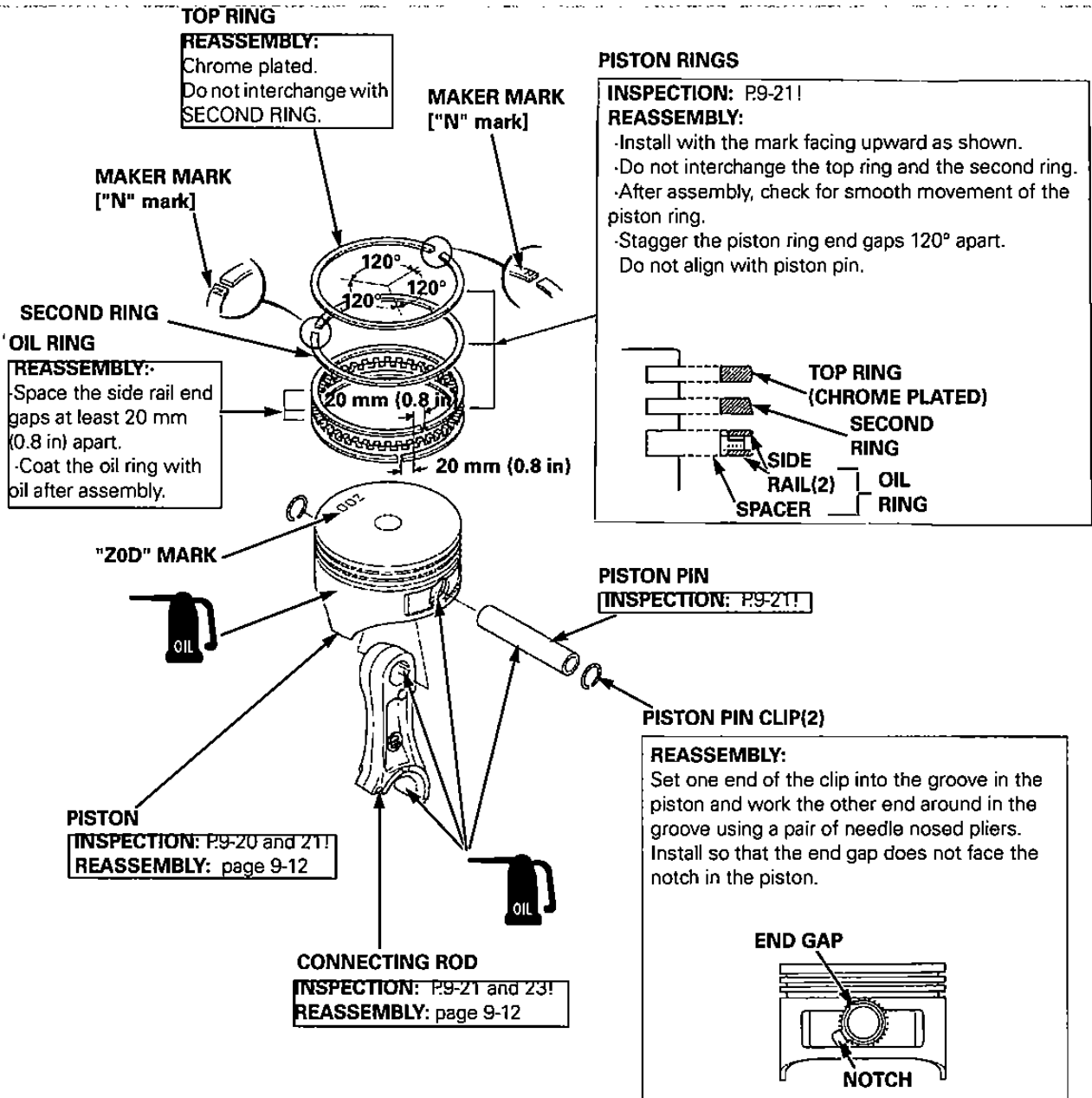

CAM PULLY/CRANKSHAFT/PISTON/CYLINDER BARREL

Piston/Connecting rod reassembly:

1. Apply oil to the piston pin hole and the connecting rod small hole.
2. Install the connecting rod in the piston so that the "ZOD" mark on the piston head points down when the longer side of the connecting rod long end is facing to the right as shown.
3. Apply oil to the piston pin and install it in the piston.
4. Install new piston pin clips.
5. Install the piston/connecting rod assembly in the cylinder barrel (page 9-8).

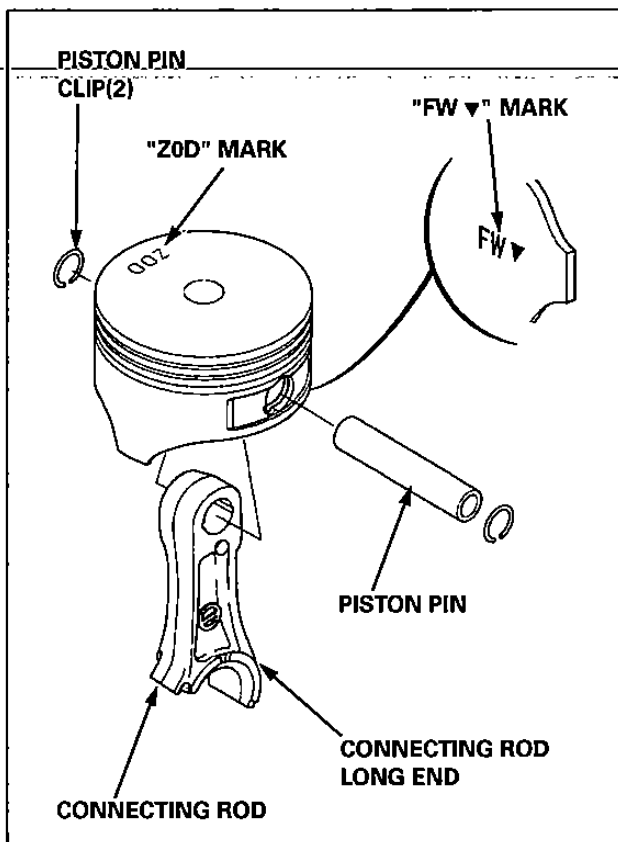

VALVES

DISASSEMBLY/REASSEMBLY

Remove the crankcase cover, crankshaft and cylinder barrel (page 9-6).

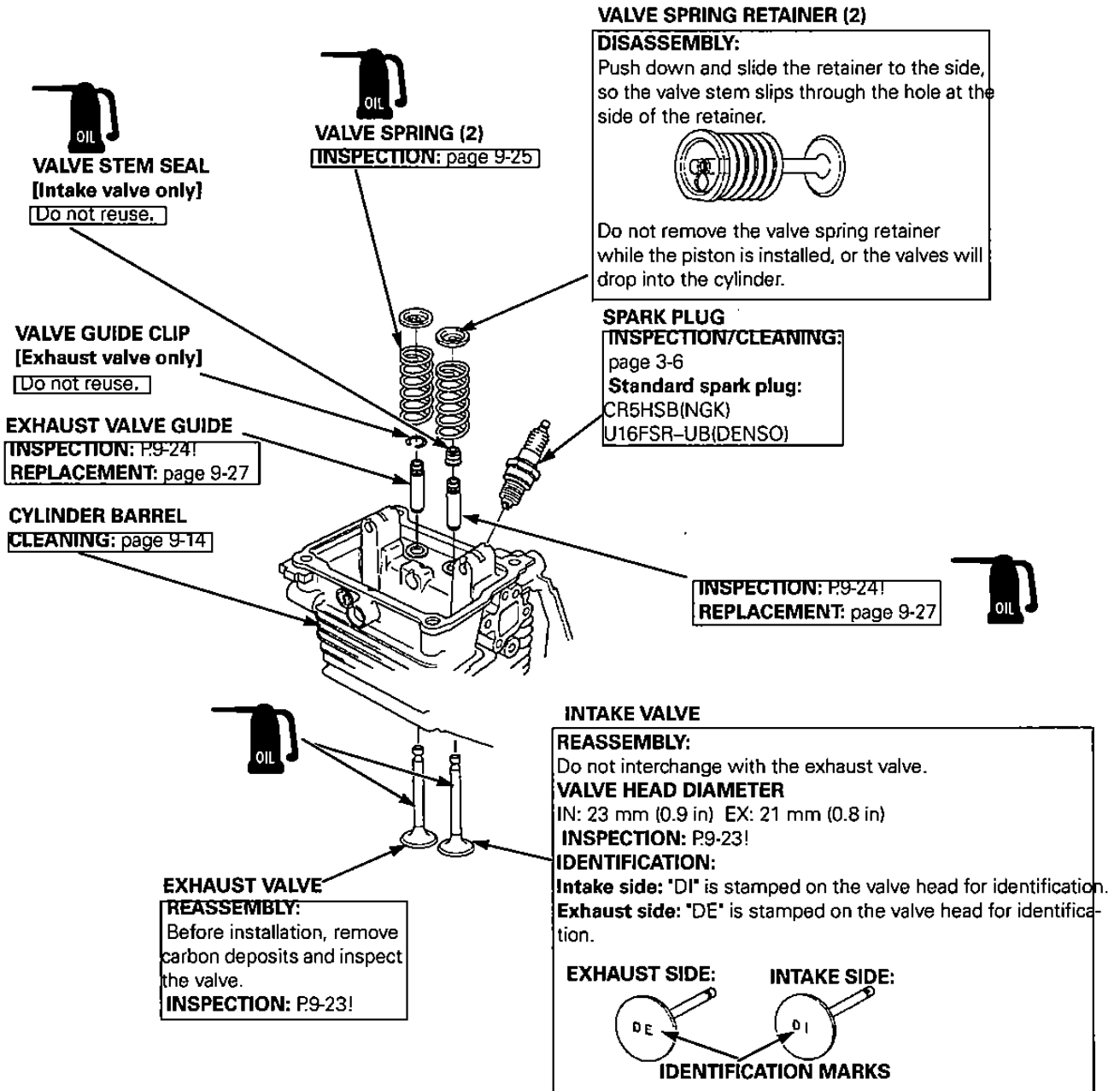

CAM PULLY/CRANKSHAFT/PISTON/CYLINDER BARREL

Cylinder barrel combustion chamber cleaning:

1. Prepare a cylinder of thick paper or equivalent material, with a diameter large enough to fit against the inner wall of the cylinder, and insert it into the cylinder for protection.
2. Attach the cleaning brush (commercially available) to an electric drill and clean the combustion chamber.

NOTICE

- Be sure to insert thick paper into the cylinder to protect the inner wall of the cylinder during cleaning of the combustion chamber.
- Do not press the cleaning brush with force against the combustion chamber.

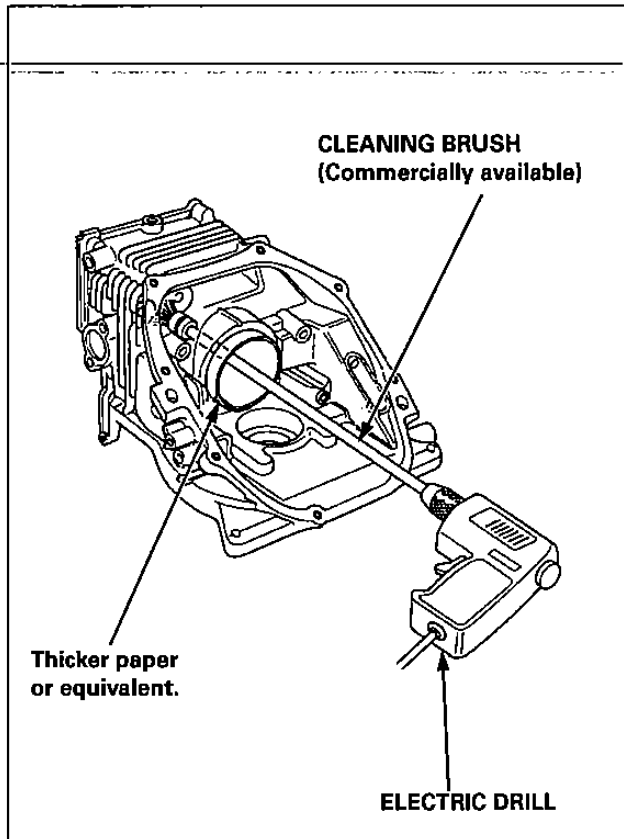

GOVERNOR

DISASSEMBLY/REASSEMBLY

 Type with oil alert only

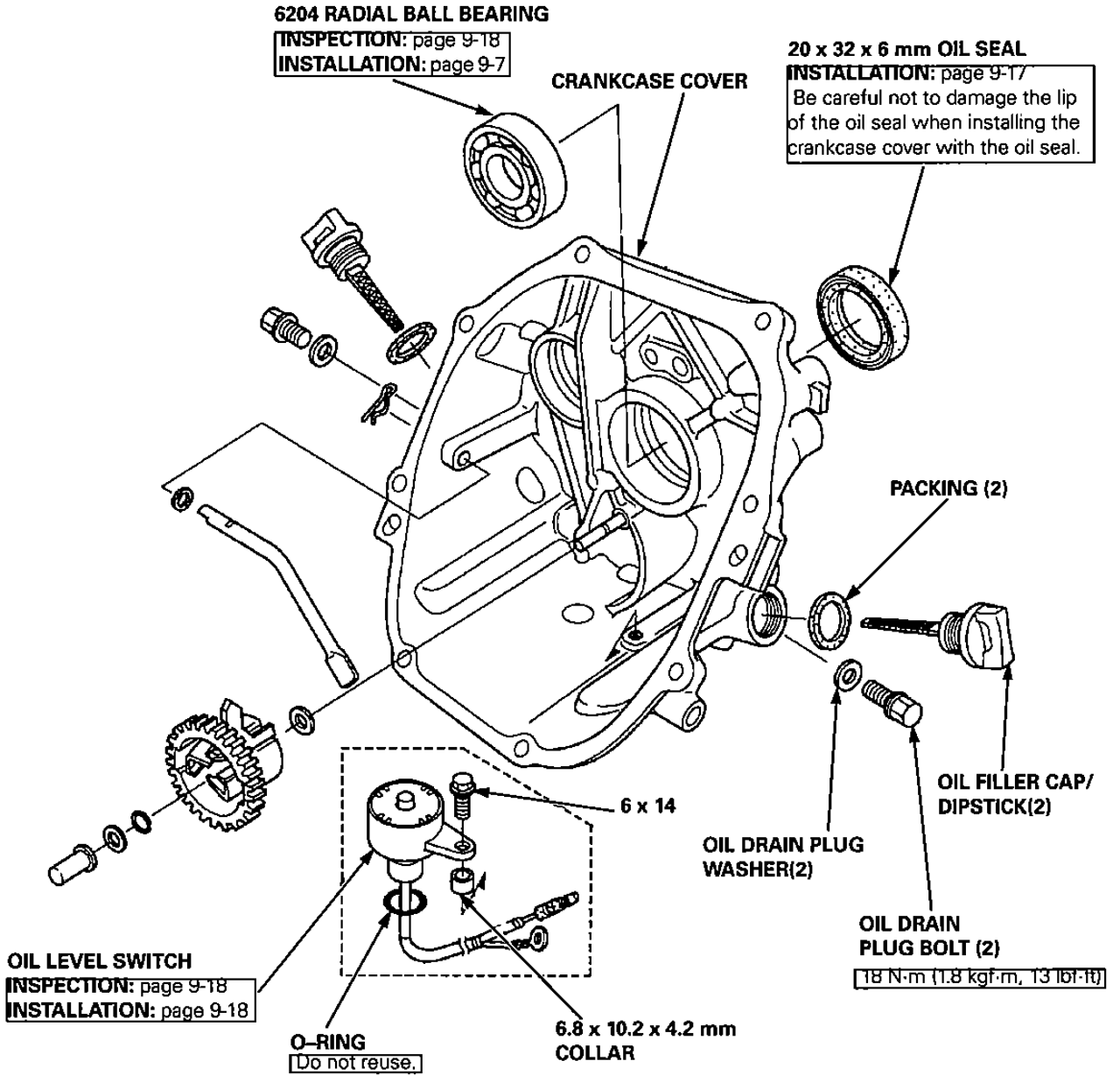

CAM PULLY/CRANKSHAFT/PISTON/CYLINDER BARREL

REASSEMBLY:

-Install the lock pin immediately after installing the governor arm shaft, and move the shaft over against the governor slider.
 -The lock pin must be installed with the straight side of the pin against the groove in the shaft.

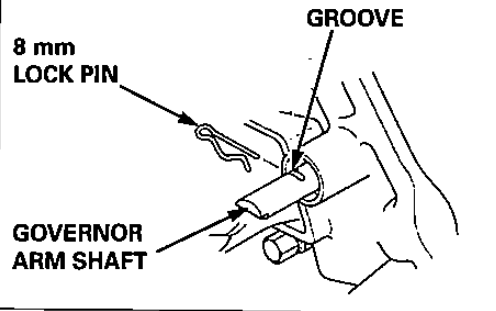

6 mm OIL WASHER
REASSEMBLY:
 Install inside the cover

GOVERNOR ARM SHAFT

6 mm WASHER

6 mm THRUST WASHER

GOVERNOR SLIDER

REASSEMBLY:
 Spread the governor weights to install the slider; then check to be sure slider moves smoothly.

GOVERNOR HOLDER CLIP

REASSEMBLY:
 Insert firmly into the shaft groove.

GOVERNOR WEIGHT HOLDER ASSEMBLY

REASSEMBLY:
 -Before installing, check for wear and damage of the gear.
 -Check that the weight move freely.
 -Be sure to install the governor weight before installing the crankshaft.

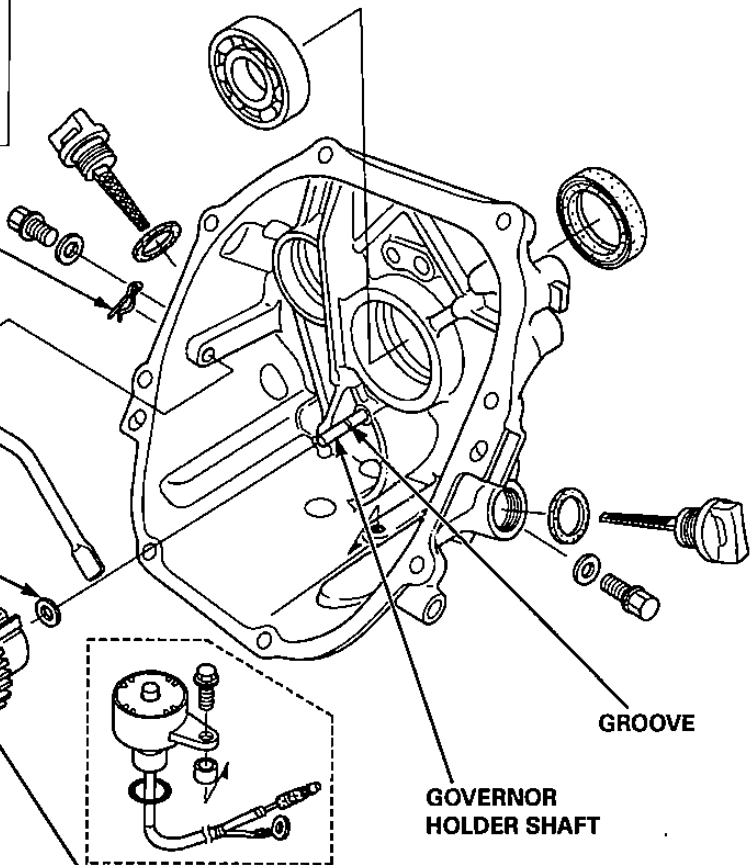

CAM PULLY/CRANKSHAFT/PISTON/CYLINDER BARREL

20 x 32 x 6 mm Oil seal installation:

1. Apply oil to the outside of the new oil seal.
2. Install the new oil seal on the crankcase cover using the special tools as shown.

TOOLS:

Driver	07749-0010000
Attachment, 32 x 35 mm	07746-0010100
Pilot, 20 mm	07746-0040500

3. After installation, apply grease to the lip.
4. Install the 6204 radial ball bearing.

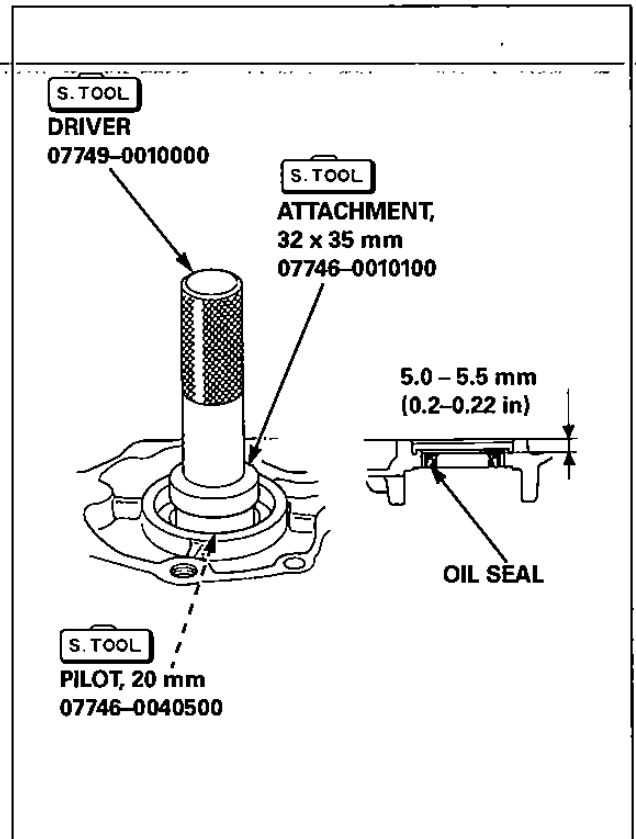

6204 Radial ball bearing installation:

1. Apply oil to the circumference of a new radial ball bearing.
2. Press the radial ball bearing in the crankcase cover using the special tools and hydraulic press.

TOOLS:

Driver	07749-0010000
Attachment, 42 x 47 mm	07746-0010100
Pilot, 20 mm	07746-0040500

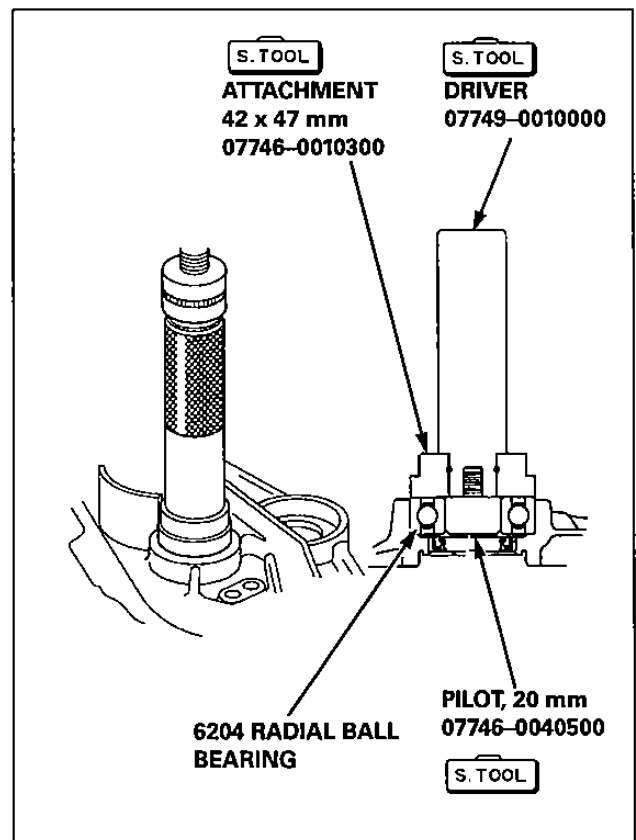

CAM PULLY/CRANKSHAFT/PISTON/CYLINDER BARREL

Oil level switch installation:

1. Install the oil level switch (page 9-15)
2. Set the oil level switch wire between the ribs of the cylinder barrel as shown.

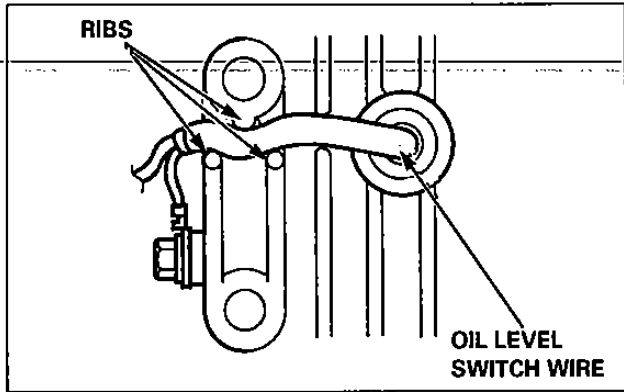

INSPECTION

OIL LEVEL SWITCH

Check continuity between the yellow wire and ground with an ohmmeter.

1. Hold the switch in its normal position. The ohmmeter should read zero resistance.
2. Hold the switch upside down. The ohmmeter should read infinite (∞) resistance.
3. Inspect the float by dipping the switch into a container of oil. The ohmmeter reading should go from zero to infinity as the switch is lowered.

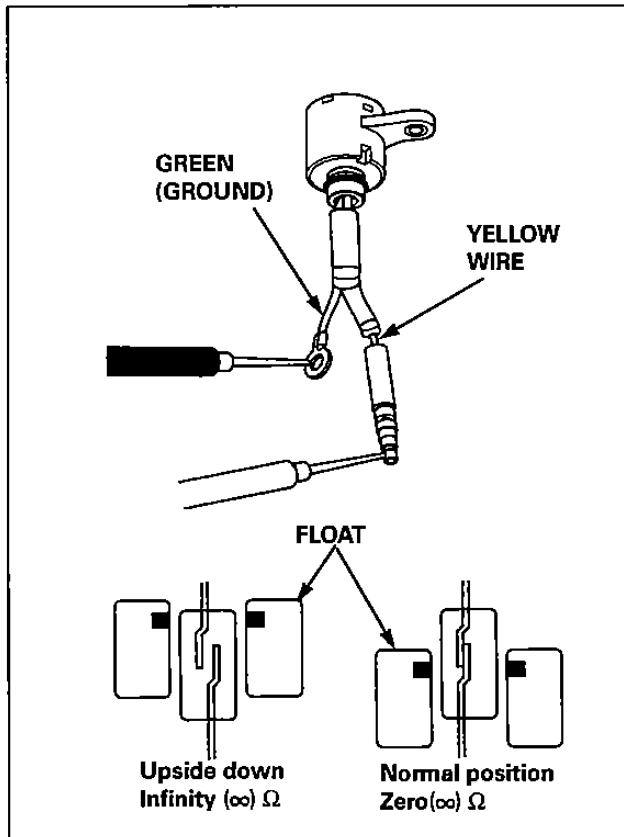

CAM PULLEY/CRANKSHAFT/PISTON/CYLINDER BARREL

6204 RADIAL BALL BEARING

Turn the inner race of the bearing with your finger. The bearing should turn smoothly and quietly. Also check that the bearing outer race fits in place.

Replace the bearing if the inner race does not turn smoothly, quietly, or if it fits very loosely.

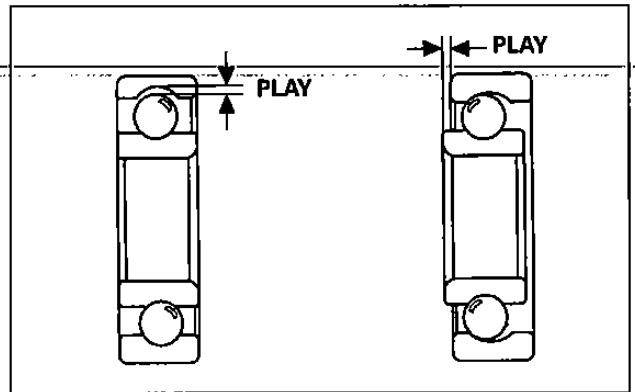

CAM PULLEY

Decompressor weight inspection:

Before installing, inspect for a worn or weakened spring, and check that the decompressor weight moves smoothly.

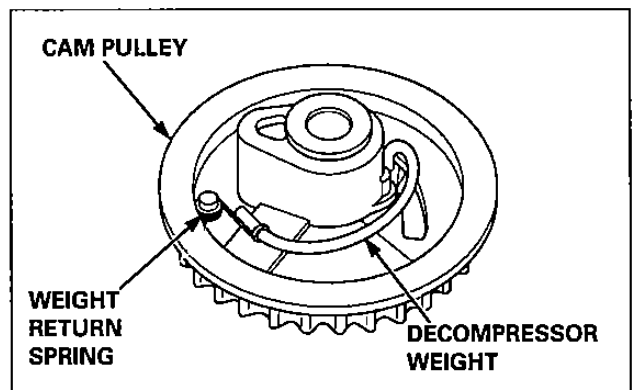

CAM PULLEY CAM HEIGHT

Standard	Service limit
36.483 mm (1.4363 in)	35.483 mm (1.3970 in)

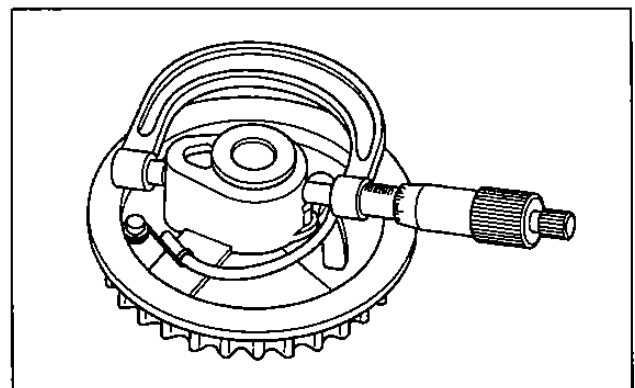

CAM PULLEY I.D. (BEARING)

Standard	Service limit
10.027 – 10.057 mm (0.3948 – 0.3959 in)	10.075 mm (0.3967 in)

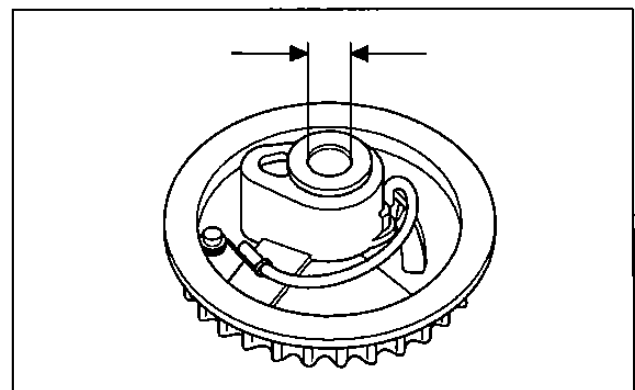

CAM PULLY/CRANKSHAFT/PISTON/CYLINDER BARREL

CAM PULLEY SHAFT O.D.

Standard	Service limit
9.972 – 9.987 mm	9.920 mm
(0.3926 – 0.3932 in)	(0.3906 in)

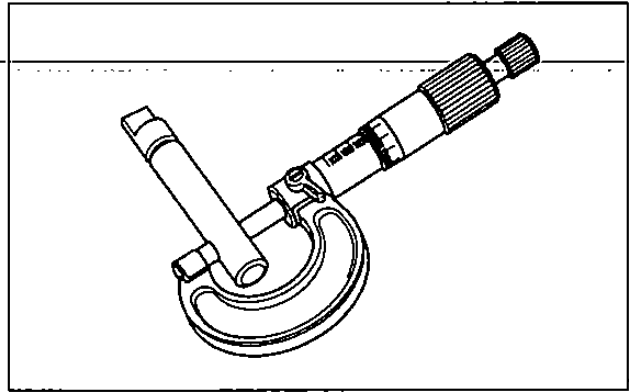

ROCKER ARM I.D.

Standard	Service limit
6.000 – 6.018 mm	6.043 mm
(0.2362 – 0.2369 in)	(0.2379 in)

ROCKER ARM SHAFT BEARING I.D.

Standard	Service limit
6.000 – 6.018 mm	6.043 mm
(0.2362 – 0.2369 in)	(0.2379 in)

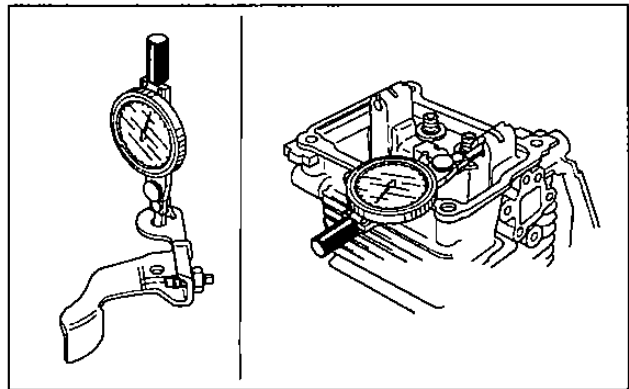

ROCKER ARM SHAFT O.D.

Standard	Service limit
5.960 – 5.990 mm	5.953 mm
(0.2346 – 0.2358 in)	(0.2344 in)

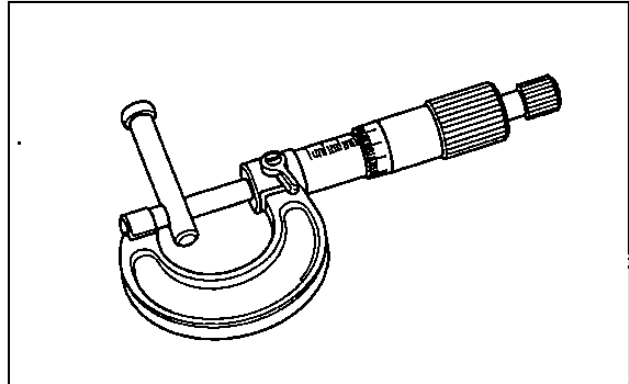

CAM PULLY/CRANKSHAFT/PISTON/CYLINDER BARREL

CYLINDER I.D.

Measure and record the cylinder I.D. at three levels in both the "X" axis (perpendicular to crankshaft) and the "Y" axis (parallel to crankshaft). Take the maximum reading to determine cylinder wear and taper.

Standard	Service limit
56.000 – 56.015 mm (2.2047 – 2.2053 in)	56.165 mm (2.2112 in)

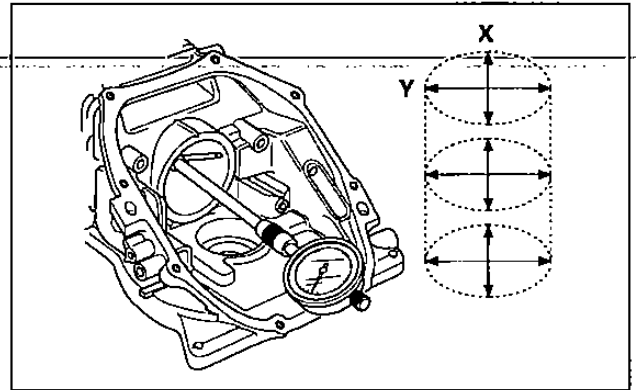

PISTON SKIRT O.D.

Measure and record the piston O.D. at a point 10 mm (0.4 in) from the bottom of the skirt and 90° to the piston pin bore.

Standard	Service limit
55.965 – 55.985 mm (2.2033 – 2.2041 in)	55.85 mm (2.199 in)

PISTON-TO-CYLINDER CLEARANCE

Standard	Service limit
0.015 – 0.050 mm (0.0006 – 0.0020 in)	0.120 mm (0.0047 in)

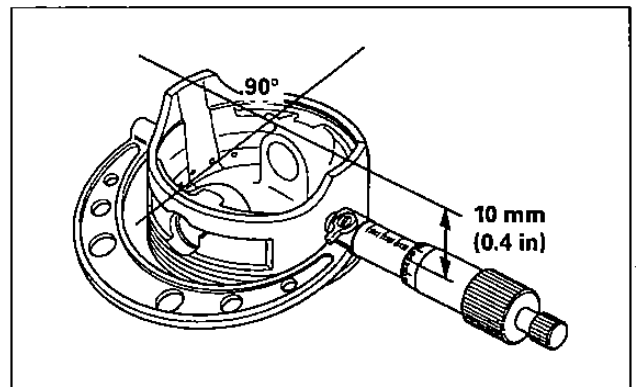

PISTON PIN BORE I.D.

Standard	Service limit
13.002 – 13.008 mm (0.5119 – 0.5121 in)	13.048 mm (0.5137 in)

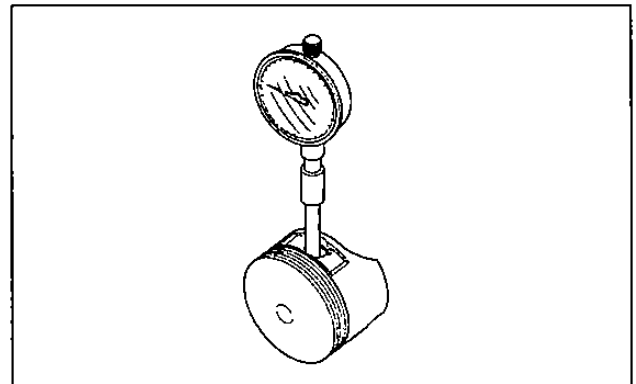

CAM PULLY/CRANKSHAFT/PISTON/CYLINDER BARREL

PISTON PIN O.D.

Standard	Service limit
12.994 – 13.000 mm (0.5116 – 0.5118 in)	12.954 mm (0.5100 in)

PISTON-TO-PISTON PIN BORE CLEARANCE

Standard	Service limit
0.002 – 0.014 mm (0.0001 – 0.0006 in)	0.080 mm (0.0031 in)

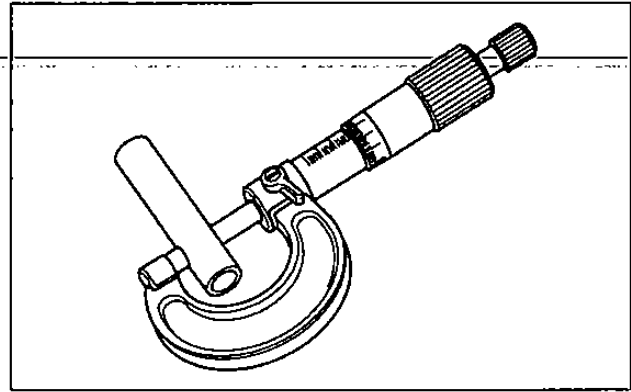

PISTON RING WIDTH

	Standard	Service limit
Top	0.970 – 0.990 mm (0.0382 – 0.0390 in)	0.940 mm (0.0370 in)
Second	1.170 – 1.190 mm (0.0461 – 0.0469 in)	1.140 mm (0.0449 in)

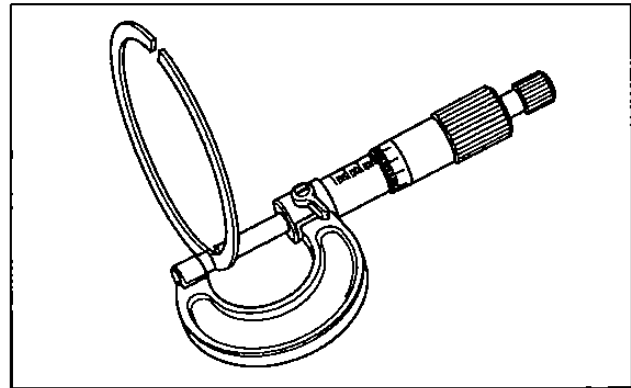

PISTON RING SIDE CLEARANCE

	Standard	Service limit
Top/Second	0.015 – 0.050 mm (0.0006 – 0.0020 in)	0.120 mm (0.0047 in)

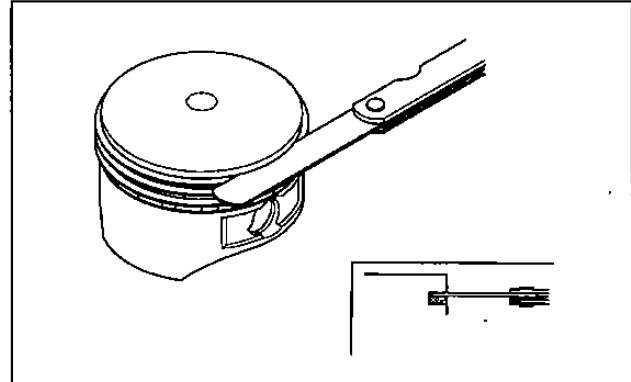

CAM PULLY/CRANKSHAFT/PISTON/CYLINDER BARREL

PISTON RING END GAP

Before measurement, be sure to set the ring in the cylinder securely using the piston.

	Standard	Service limit
Top	0.15 – 0.30 mm (0.006 – 0.012 in)	0.60 mm (0.024 in)
Second	0.30 – 0.45 mm (0.012 – 0.018 in)	0.75 mm (0.030 in)

If the measurement is too large, install a new piston ring and measure again. Then, measure the cylinder sleeve I.D. (P.9-201).

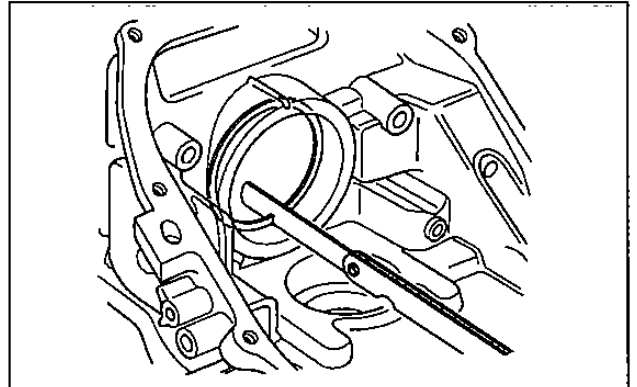

CONNECTING ROD SMALL END I.D.

Standard	Service limit
13.005 – 13.020 mm (0.5120 – 0.5126 in)	13.070 mm (0.5146 in)

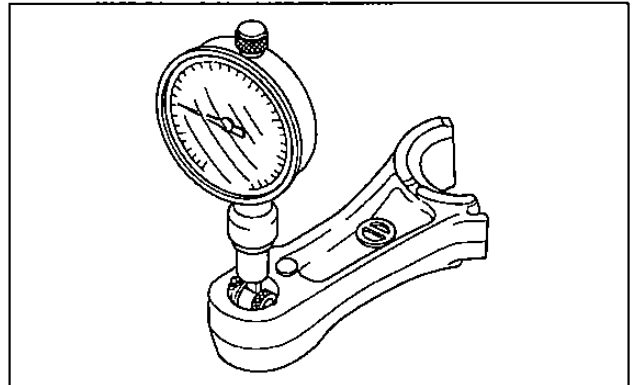

CONNECTING ROD BIG END I.D.

Standard	Service limit
24.000 – 24.013 mm (0.9449 – 0.9454 in)	24.040 mm (0.9465 in)

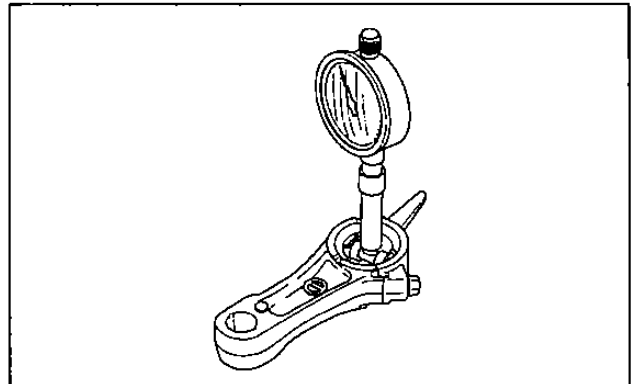

CAM PULLY/CRANKSHAFT/PISTON/CYLINDER BARREL

CRANK PIN O.D.

Standard	Service limit
23.970 – 23.980 mm (0.9437 – 0.9441 in)	23.920 mm (0.9417 in)

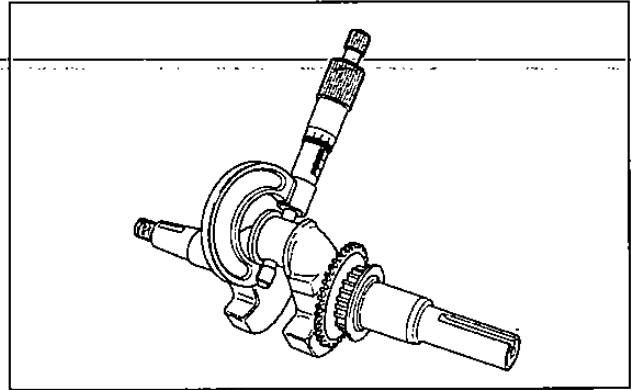

CONNECTING ROD BIG END AXIAL CLEARANCE

Measure the clearances with a feeler gauge.

Standard	Service limit
0.1 – 0.4 mm (0.004 – 0.016 in)	0.800 mm (0.0315 in)

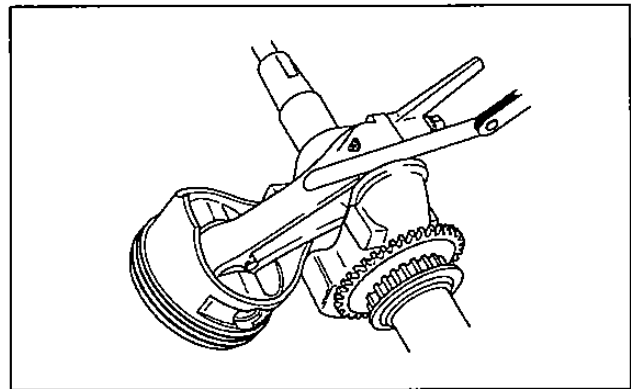

CONNECTING ROD BIG END OIL CLEARANCE

1. Wipe oil off the crank pin and connecting rod bearing mating surface.

2. Place the plastigauge on the crank pin.

Set the connecting rod and cap, and tighten the connecting rod bolts to the specified torque.

Do not rotate or move the rod.

TORQUE: 5 N·m (0.5 kgf·m, 3.6 lbf·ft)

- Place the plastigauge axially.
- Tighten the two connecting rod bolts equally while holding the crankshaft to keep it from turning.

3. Remove the connecting rod cap and measure the plastigauge with the scale.

Standard	Service limit
0.020 – 0.043 mm (0.0008 – 0.0017 in)	0.100 mm (0.0039 in)

4. If the clearance exceeds the service limit, replace the connecting rod and recheck the clearance.

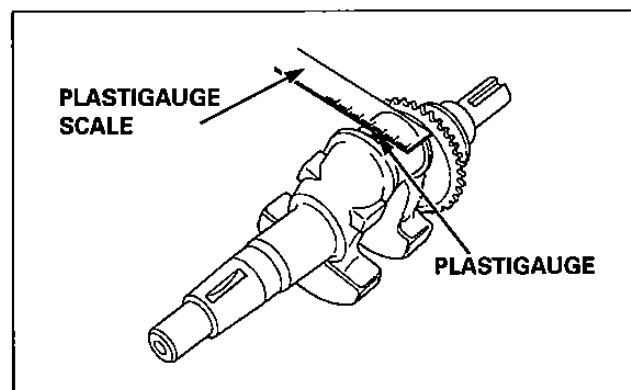
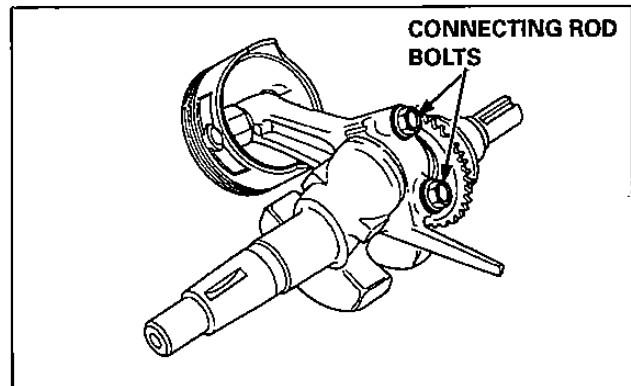

VALVE SPRING FREE LENGTH

Standard	Service limit
25.8 mm (1.02 in)	24.900 mm (0.9803 in)

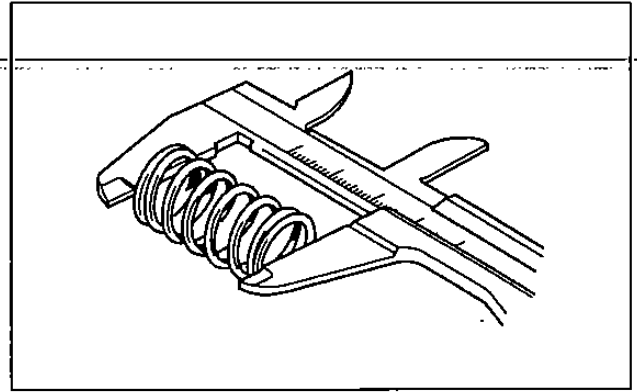

VALVE FACE/STEM O.D.

Inspect each valve face for pitting or wear irregularities. Inspect each valve stem for bending or abnormal stem wear. Replace the valve if necessary.

Measure and record each valve stem O.D.

	Standard	Service limit
IN	3.970 – 3.985 mm (0.1563 – 0.1569 in)	3.900 mm (0.1535 in)
EX	3.935 – 3.950 mm (0.1549 – 0.1555 in)	3.880 mm (0.1528 in)

Replace the valves if their O.D. is smaller than the service limit.

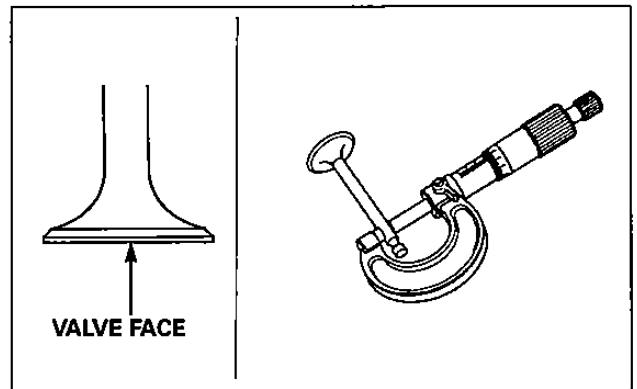

VALVE GUIDE I.D.

Using the valve guide reamer (special tool), ream the valve guides to remove any carbon deposits before measuring.

Measure and record each valve stem I.D.

	Standard	Service limit
IN/EX	4.000 – 4.018 mm (0.1575 – 0.1582 in)	4.060 mm (0.1598 in)

Replace the valve guides if they are over the service limit.(page 9-27)

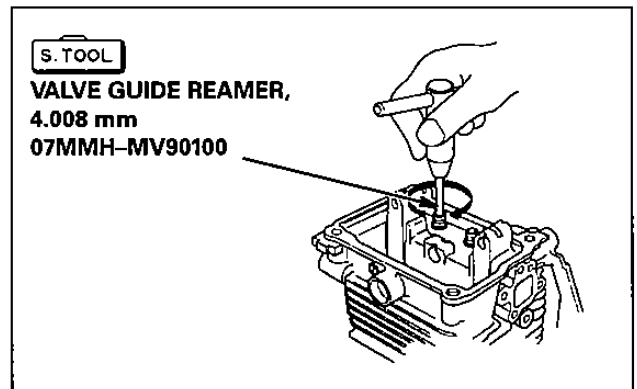

VALVE STEM-TO-VALVE GUIDE CLEARANCE

Subtract each valve stem O.D. from the corresponding guide I.D. to find the clearance.

	Standard	Service limit
IN	0.015 – 0.048 mm (0.0006 – 0.0019 in)	0.098 mm (0.0039 in)
EX	0.050 – 0.083 mm (0.0020 – 0.0033 in)	0.120 mm (0.0047 in)

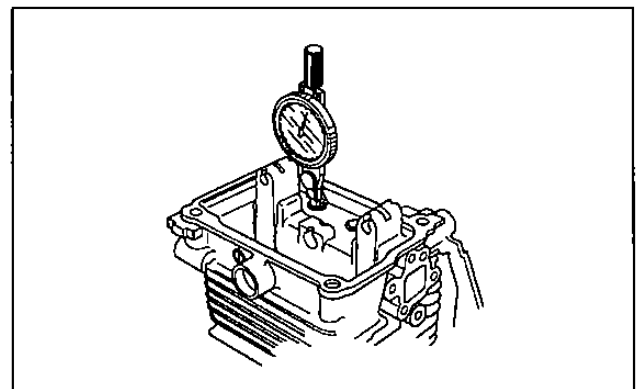

CAM PULLY/CRANKSHAFT/PISTON/CYLINDER BARREL

If the stem-to-guide clearance exceeds the service limit, determine if the new guide with standard dimensions would bring the clearance within tolerance. If so, replace any guide as necessary and ream to fit. If the stem-to-guide clearance exceeds the service limit with new guides, replace the valves as well.

Recondition the valve seats whenever the valve guides are replaced (page 9-29)

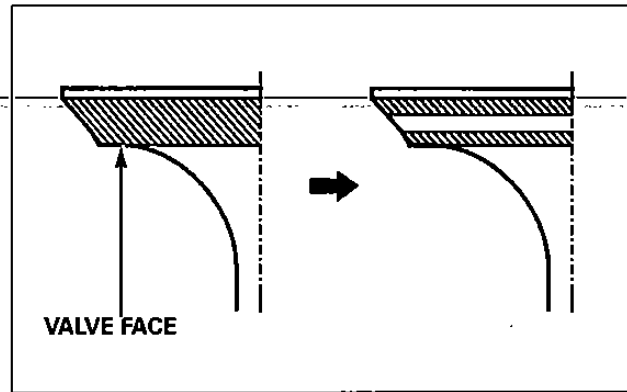

VALVE SEAT WIDTH

Measure the valve seat width.

	Standard	Service limit
IN/EX	0.7 mm (0.028 in)	1.800 mm (0.0709 in)

If the valve seat width is under the standard, or over the service limit, or if the valve seat is too high/low, recondition the valve seat (page 9-29)

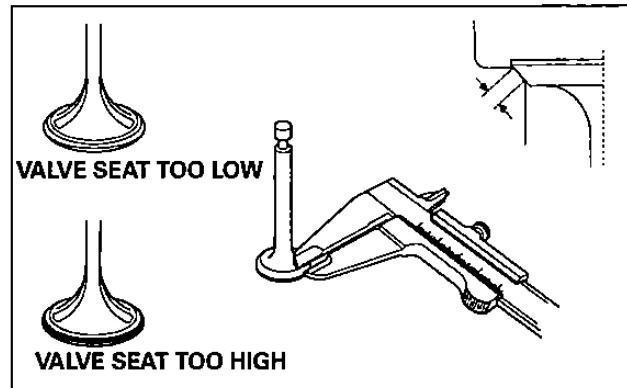

VALVE GUIDE REPLACEMENT

1. Chill the replacement valve guides in the freezer section of a refrigerator for about an hour.
2. Use a hot plate or oven to heat the cylinder barrel evenly to 150 °C (300 °F). Check the temperature with a temperature indicating stick (available at welding supply store) or equivalent.

NOTICE

- Do not use a torch to heat the cylinder barrel; warpage of the cylinder barrel may result.
 - Do not get the heat hotter than 150° C(300° F); excessive heat may loosen the valve seats.
3. Remove the heated cylinder barrel from hot plate, and support it with wooden blocks. Wear heavy gloves to protect your hands.
 4. Drive the valve guides out of the cylinder barrel from the combustion chamber side.

TOOL:

Valve guide driver, 3.6 x 8.0 mm 07JMD-KY20100

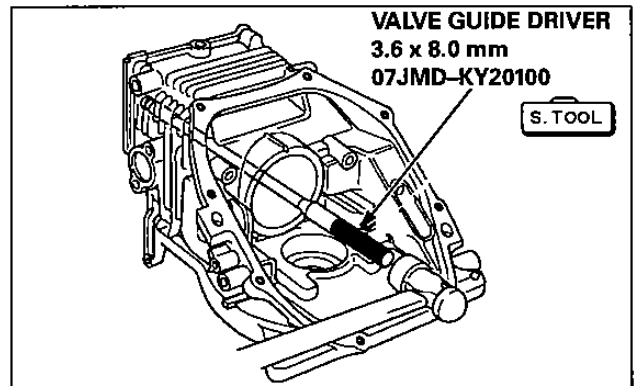

NOTICE

Be careful to avoid damaging the cylinder barrel when driving out the valve guides.

5. Allow the cylinder barrel to cool to room temperature. Clean and inspect the valve guide bores in the cylinder barrel. Wash out any foreign material.
6. Use a hot plate or oven to heat the cylinder barrel evenly to 150 °C (300 °F). Check the temperature with a temperature indicating stick or equivalent.

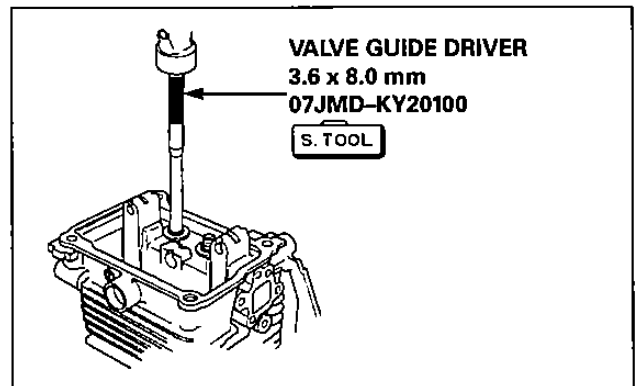

7. Install the new valve guides from the valve spring side of the cylinder barrel.

TOOL:

Valve guide driver, 3.6 x 8.0 mm 07JMD-KY20100

Exhaust side: Drive the exhaust valve guide until the clip is fully seated as shown.

Intake side: Drive the intake valve guide to the specified height, measured from the top of the valve guide to the cylinder barrel casting as shown.

Intake side: Drive the intake valve guide to the specified height, measured from the top of the valve guide to the cylinder barrel casting as shown.

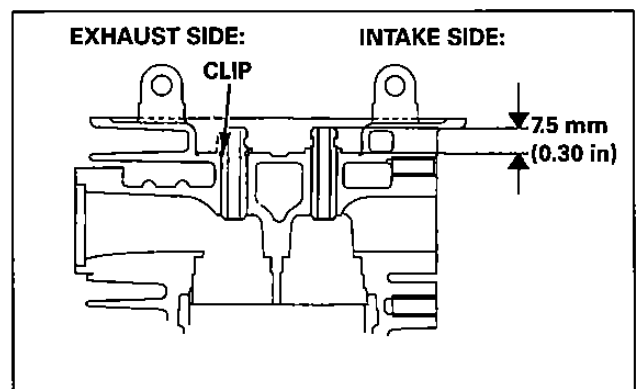

Valve guide extrusion amount	IN	7.5 mm (0.30 in)
------------------------------	----	------------------

8. After installation, inspect the valve guides for damage. Replace any damaged valve guide.

CAM PULLY/CRANKSHAFT/PISTON/CYLINDER BARREL

VALVE GUIDE REAMING

For best results, be sure the cylinder barrel is at room temperature before reaming valve guides.

1. Coat the reamer and valve guide with cutting oil.
2. Rotate the reamer clockwise through the valve guide for the full length of the reamer.
3. Continue to rotate the reamer clockwise while removing it from the valve guide.

TOOL:

Valve guide reamer, 4.008 mm 07MMH-MV90100

4. Thoroughly clean the cylinder barrel to remove any cutting residue.
5. Check the valve guide bore; it should be straight, round and centered in the valve guide, insert the valve and check operation. If the valve does not operate smoothly, the guide may have been bent during installation. Replace the valve guide if it is bent or damaged.
6. Check the Valve Guide-to-Stem Clearance (page 9-25)

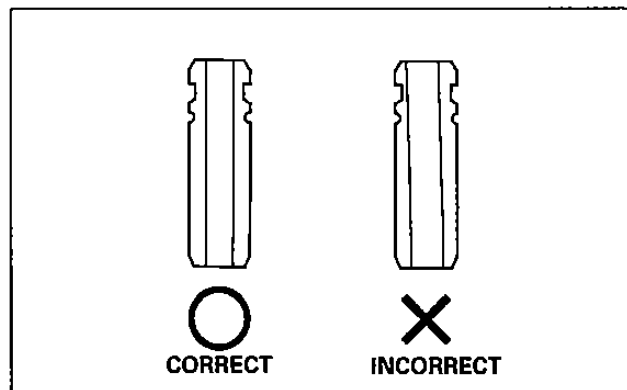
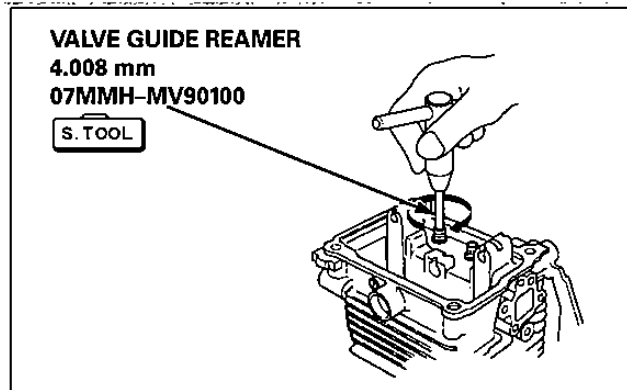

VALVE SEAT RECONDITIONING

1. Thoroughly clean the combustion chamber and valve seats to remove carbon deposits (P.9-13)
2. Apply a light coat of Prussian Blue compound or erasable felt-tipped marker ink to the valve faces.
3. Insert the valves, and then lift them and snap them closed against their seats several times. Be sure the valve does not rotate on the seat. The transferred marking compound will show any area of the seat that is not concentric.

NOTICE

Follow the valve seat cutter manufacturer's instructions.

4. Using a 45° cutter, remove enough material to produce a smooth and concentric seat.

Turn the cutter clockwise, never counterclockwise. Continue to turn the cutter as you lift it from the valve seat.

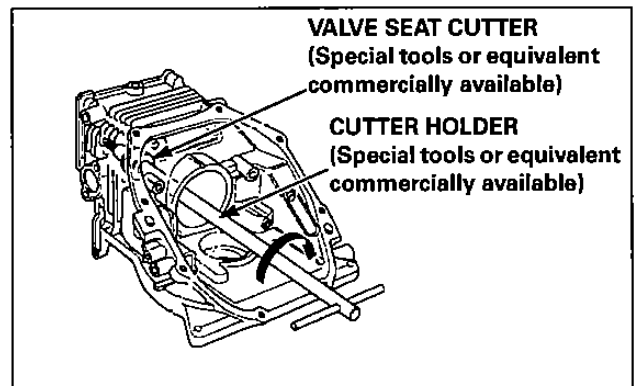
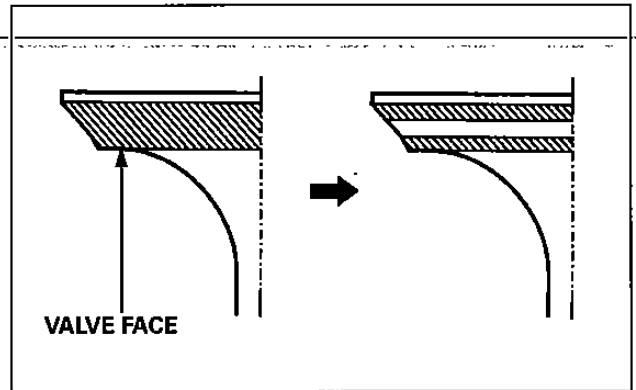

TOOL:

(Special tools or equivalent commercially available)

Valve seat cutter, 45° 24.5 mm (IN)	07780-0010100
Valve seat cutter, 45° 24 mm (EX)	07780-0010600
Valve seat cutter, 32° 25 mm (IN)	07780-0012000
Valve seat cutter, 32° 24 mm (EX)	07780-0012500
Valve seat cutter, 60° 24 mm (IN/EX)	070PH-Z0D0100
Cutter holder, 4.0 x 400 mm	070PH-Z0D0200

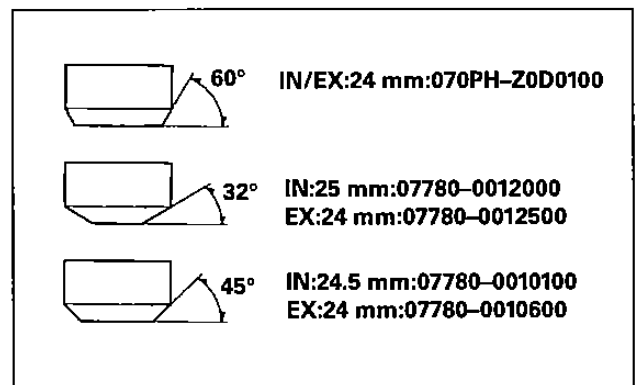

5. Use the 32° and 60° cutters to narrow and adjust the valve seat so that it contacts the middle of the valve face.

The 32° cutter removes material from the top edge.

The 60° cutter removes material from the bottom edge.

Be sure that the width of the finished valve seat is within specification (P.9-281)

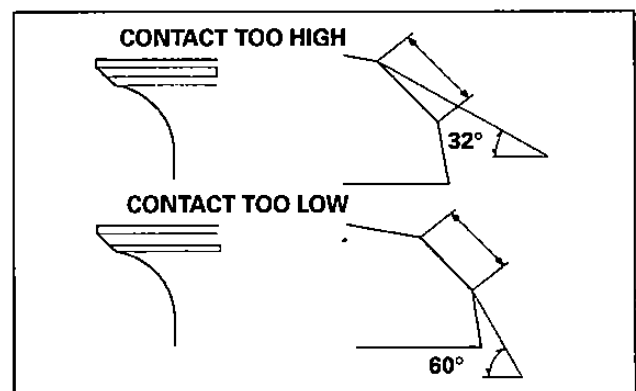

CAM PULLY/CRANKSHAFT/PISTON/CYLINDER BARREL

	Standard	Service limit
IN/EX	0.7 mm (0.028 in)	1.800 mm (0.0709 in)

6. Make a light pass with 45° cutter to remove any possible burrs at the edges of the seat.
7. After resurfacing the seat, inspect for even valve seating. Apply Prussian Blue compound or erasable felt-tipped marker ink to the valve faces. Insert the valves, and then lift them and snap them closed against their seats several times. Be sure the valve does not rotate on the seat. The seating surface, as shown by the transferred marking compound, should have good contact all the way around.
8. Lap the valves into their seats, using a 4 mm tube as shown and lapping compound (commercially available).

NOTICE

To avoid severe engine damage, be sure to removal all lapping compound from the combustion chamber before assembly.

9. Check valve clearance after assembly (page 3-7)

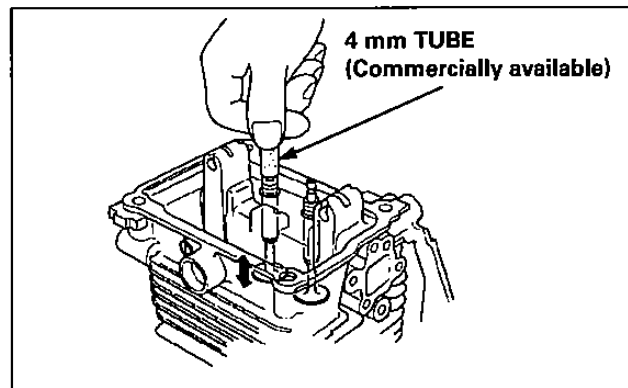
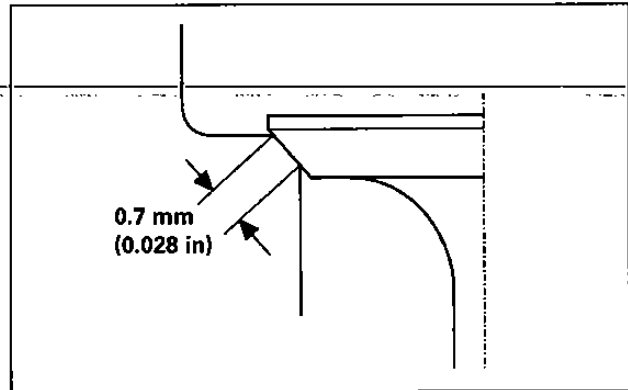

10. INDEX

AIR CLEANER		MAINTENANCE STANDARDS	2-3
FUEL SYSTEM	4-4	MUFFLER	6-2
MAINTENANCE	3-5	OIL ALERT ESS (TYPE WITH OIL ALERT)	7-6
BREATHER COVER A/B	8-6	OIL ALERT (TYPE WITH OIL ALERT)	3-2
CAM PULLY	9-2	PERFORMANCE CURVE	1-3
CARBURETOR		PISTON	9-11
FUEL SYSTEM	4-6	PTO DIMENSIONAL DRAWINGS	1-5
MAINTENANCE	3-8	RECOIL STARTER/FAN COVER	
CONTROL BASE/GOVERNOR ARM	5-2	/ENGINE STOP SWITCH	7-2
CRANKCASE COVER/CRANKSHAFT		SERIAL NUMBER LOCATION	2-2
/CYLINDER BARREL	9-6	SPARK ARRESTER (OPTIONAL PARTS)	3-11
DIMENSIONAL DRAWINGS	1-4	SPARK PLUG	3-6
ENGINE OIL	3-3	SPECIAL TOOLS	2-5
FLYWHEEL/IGNITION COIL	8-2	SPECIFICATIONS	1-2
FUEL FILTER/FUEL TANK/FUEL TUBE	3-10	SYMBOLS USED IN THIS MANUAL	2-2
FUEL TANK	4-2	TORQUE VALUES	2-4
GOVERNOR		TROUBLESHOOTING	2-6
CAM PULLY/CRANKSHAFT/PISTON		VALVE CLEARANCE	3-7
/CYLINDER BARREL	9-15	VALVE GUIDE REPLACEMENT	9-27
MAINTENANCE	3-9	VALVE SEAT RECONDITIONING	9-29
HARNESS ROUTING	2-7	VALVES	9-13
INSPECTION	9-18	WIRING DIAGRAMS	1-6
MAINTENANCE SCHEDULE	3-2		